

SONICVARE

LIVEN

Texture Lab

User's Manual

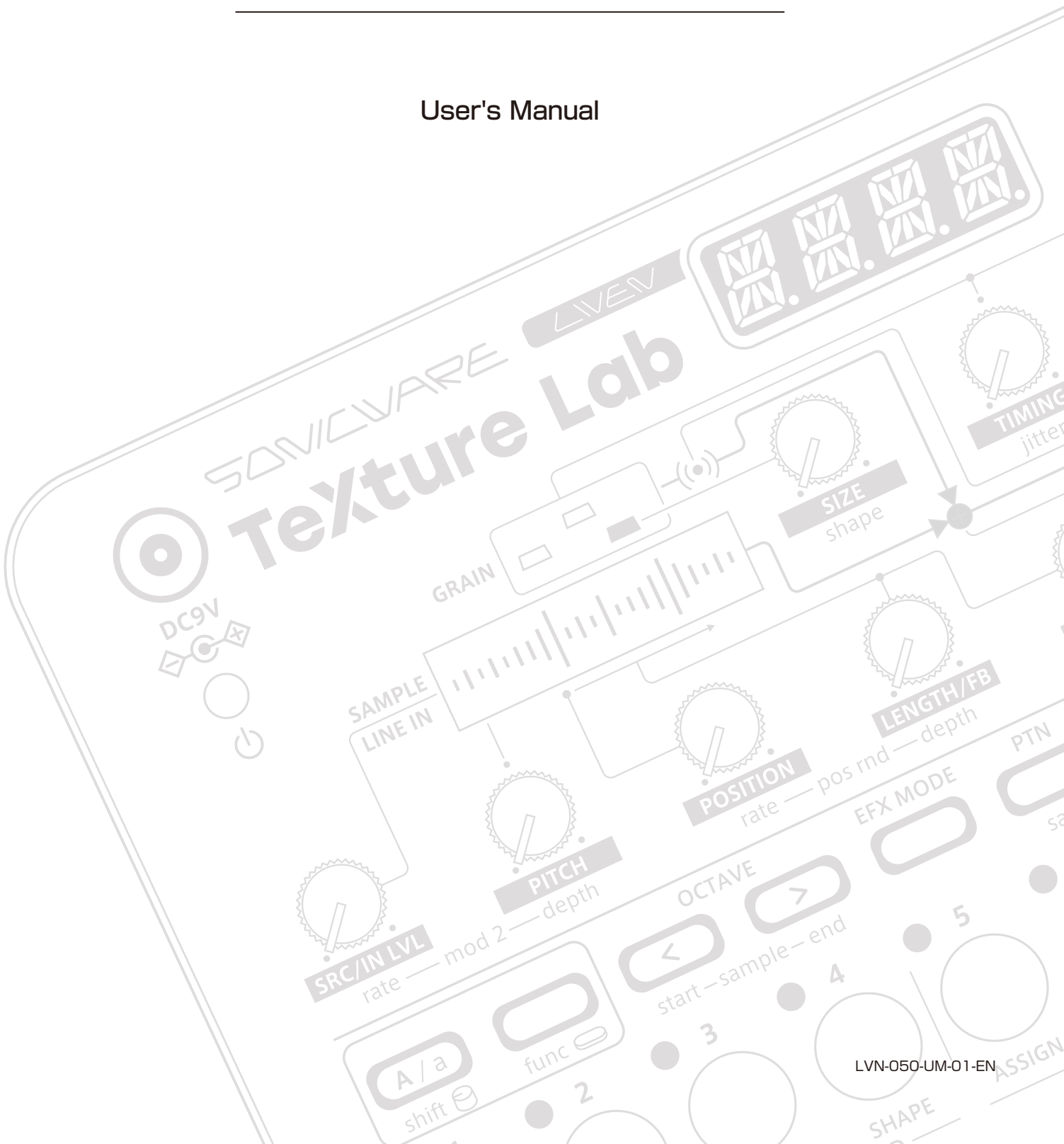

FCC regulation warning (for USA)

Note: This equipment has been tested and found to comply with the limits for a Class B digital device, pursuant to part 15 of the FCC Rules. These limits are designed to provide reasonable protection against harmful interference in a residential installation. This equipment generates, uses and can radiate radio frequency energy and, if not installed and used in accordance with the instructions, may cause harmful interference to radio communications. However, there is no guarantee that interference will not occur in a particular installation. If this equipment does cause harmful interference to radio or television reception, which can be determined by turning the equipment off and on, the user is encouraged to try to correct the interference by one or more of the following measures:

- Reorient or relocate the receiving antenna.
- Increase the separation between the equipment and receiver.
- Connect the equipment into an outlet on a circuit different from that to which the receiver is connected.
- Consult the dealer or an experienced radio/TV technician for help.

Legal disclaimers

Sonicware Inc. (hereafter, "SONICWARE") strives to assure that this document is as accurate and current as possible, but will bear no responsibility for any compensation claims or losses due to content included in this document. Moreover, information in this document could be changed without notice. SONICWARE retains the right to change product specifications and programs at any time. SONICWARE will bear no responsibility for any errors depicted in this document. SONICWARE will bear no responsibility for any losses resulting from the use of this information, functions or performance, regardless of contracts, lack of caution or other conduct.

Copyrights and registered trademarks

- SONICWARE is a registered trademark of Sonicware Inc.
- MIDI is a registered trademark of the Association of Musical Electronics Industry (AMEI).
- Other company names, product names, standard names and registered trademarks in this document are the property of their respective owners.
- All the trademarks and registered trademarks in this document are not intended to violate the copyrights of their owners, but rather are included for the purpose of identification only.
- Recording from copyrighted sources, including audio files, CDs, records, videos, tapes, broadcasts, streamed content and works of art, without permission of the copyright holder for any purpose other than personal use is prohibited by law.
- Sonicware Inc. will not assume any responsibility related to infringements of copyrights.

Important safety precautions

You must read the following precautions in order to use the product safely and prevent accidents.

WARNING: Failure to follow these precautions could result in serious harm to the user or even death.

- Operation using an AC adapter

Do not do anything that could exceed the ratings of outlets and other electrical wiring equipment.

Disconnect the AC adapter from the outlet when lightning occurs and when not using it for a long time.

- Operation using batteries

Use-commercially available 1.5V AA batteries.

Carefully read the precautions of the batteries being used.

Be sure to insert the batteries with +/ – ends oriented correctly.

Do not use new and old batteries together. Do not use batteries of different types together.

Remove the batteries when they will not be used for a long time.

If a leak occurs, thoroughly wipe the battery compartment and battery terminals to remove the leaked fluid.

- Do not open the case and disassemble or modify the product.
- Do not drop, strike or apply excessive force to the unit.
- Do not put liquid on or in the unit.
- Do not put foreign objects into the case.
- Do not use at a loud volume. Doing so could generate loud volumes that might lead to hearing loss.
- When transferring this unit, use the individual packing box and cushioning material that it came with when purchased new.
- When the unit is powered on, do not wrap it in cloth, plastic or other materials.
- Do not step on or apply pressure to the power cord.
- Do not use in the following environmental conditions. Doing so could cause malfunction.

Locations in direct sunlight, environments that exceed 40° C, or near stoves and other heat sources

Locations with extremely low or high temperatures

Locations with extremely high humidity or where the product could become wet

Locations with frequent vibrations or much dust or sand

- If the unit becomes broken or malfunctions, immediately turn the power off and stop using it.

Usage Precautions

Failure to follow these precautions could cause injury to the user and physical damage.

- When connecting cables or working with the power of the unit, minimize the input levels of connected devices or turn them off.
- Cleaning

If the screen or the case become dirty, wipe them gently with a soft cloth.

Do not use chemicals, including alcohol, benzene, thinner or cleansers.

If this does not clean them, wipe them with a slightly damp cloth that has been wrung out well.

Do not turn the power on until the product is completely dry.

Introduction

Thank you very much for purchasing a SONICWARE LIVEN Texture Lab.

The LIVEN Texture Lab is a granular processor capable of generating a variety of sound textures, ranging from ambient pads to chaotic experimental noises, that will push the limits of your imagination.

New sounds can be generated through intuitive operation of the 16 physical knobs and in almost any situation using battery power and the built-in speaker.

We hope you enjoy using it for many years.

Key features of the LIVEN Texture Lab

- The **granular processor** can synthesize completely new sounds by splitting, altering and reassembling any kind of source sound.
- This **multifunction unit** can be used both as a synthesizer and as an effect processor.
- The sublime **Shimmer reverb** can add a layer of reverberations an octave above the source sound.
- The **128-step sequencer** can record the movement of individual parameters.
- Well-known sound designers have provided **16 pattern presets** resulting from their explorations.

Jam in any situation

Battery power and a built-in speaker enable producing and performing anywhere

Synchronize with all kinds of devices

Clock synchronization is possible with devices that have MIDI or SYNC connectors.

Key features of the LIVEN Texture Lab

The audio SYNC function enables synchronization with Teenage Engineering Pocket Operator devices using the LINE jack.

In addition, clock synchronization signals can be bridged between different connectors. For example, MIDI clock can be generated from an input SYNC clock signal.

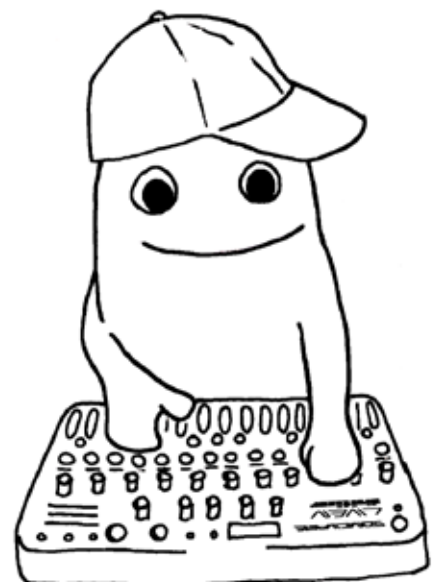

Contents

Names of parts	9	Randomizing grain size and shape	24
Connection example	9	Adjusting the mix of the sample and grain sounds	25
Starting up and shutting down	10	Modulation	26
Preparing a power supply	10	Modulation settings	26
Starting up	10	Adjusting modulation speed and depth	26
Turning the unit off	10	Modulation tempo syncing	26
Basic operations	11	Modulation destination parameter	27
Adjusting the overall volume	11	LFO waveform	27
Turning on/off the speaker	11	Envelope generator	28
Using the func button	12	Adjusting the attack and release of the granular sound	28
Using the shift button	12	Filters	29
Using the shift button hold function	12	Changing the filter type	29
Pattern overview	13	Adjusting the filter cutoff frequency	29
Pattern overview	13	Adjusting the filter resonance	29
Patterns and banks	13	Reverb	30
Basic pattern operation	14	Adjusting the reverb	30
Selecting patterns	14	Deactivating the reverb reset when changing patterns	30
Playing patterns	14	Sampling	31
Selecting pattern 17 and higher	14	Overview	31
Changing the tempo	15	Sample slot selection	31
Reloading patterns	15	Sampling - Recording	32
Pattern chain playback	16	Resampling	33
Selecting multiple patterns and playing them in order (chain playback)	16	Resampling a pattern	33
Looping chain playback	16	Sampling settings	34
Performing with the keyboard and voice modes	17	Setting auto recording	34
Performing	17	Exporting/importing samples	35
Holding keyboard notes	17	Exporting a single sample	35
Changing the velocity	17	Importing a single sample	35
Changing the octave range	18	Renaming samples	36
Changing the voice mode	18	Renaming samples	36
Changing the glide (in MONO/LEGATO mode)	19	LINE IN settings	37
Changing the arpeggiator type (in ARP mode)	20	Changing the gain	37
Granular synthesizer	21	Setting mono/stereo	37
Sample settings	22	Granular effect mode	38
Setting the interval used for the sample	22	Switching to effect mode	38
Randomizing grain generation position	23	Connecting a source to the LINE IN and adjusting its level	38
Freezing the grain generation position	23	Parameters that are different in effect mode	39
Grain settings	24		

Contents

Freezing line input	39	Random	54
Step sequencer overview	40	Random settings.....	54
Overview	40	Stutter	55
Texture Lab step sequencer features...	40	Deleting sequences	56
Creating sequences - Settings	41	Clearing steps	56
Setting the note length of one step ...	41	Clearing all note data in a sequence ...	56
Changing the sequence length.....	41	Restoring only the sound to the last saved state.....	56
Creating sequences - Step recording 42		Pattern saving	57
Basic operations	42	Saving patterns	57
Selecting steps 17 and higher	43	Initializing patterns	57
Clearing steps	44	Pattern renaming	58
Automatically advancing steps during step recording (Auto Step mode)	44	Renaming patterns.....	58
Enabling tied-note (long sound) input ...	45	Tempo overview	59
Inputting tied-notes (long sounds)	45	Setting the BPM mode.....	59
Creating sequences		Setting the pattern BPM.....	59
- Real-time recording	46	Setting the global BPM	60
Basic operations	46	Clock synchronization with external devices — Clock settings	61
Undoing the real-time recording just captured	46	Overview	61
Turning on/off the metronome	47	Setting the clock source	62
Adjusting the metronome volume	47	Setting Audio Sync output	62
Setting a pre-count	47	Setting SYNC IN polarity.....	63
Creating sequences		Setting SYNC OUT polarity	63
- Direct recording	48	Clock synchronization with external devices — Connection examples.....	64
Basic operations	48	LIVEN as clock master.....	64
Creating sequences - settings	50	External device as clock master	65
Setting the swing	50	Bridging clock signals to a different connector from an external device acting as the clock master	66
Transposing	50	MIDI	67
Parameter locking	51	Setting channels for receiving MIDI ...	67
Basic parameter locking operations 51		Setting channels for transmitting MIDI	67
Turning parameter locking on	51	Turning MIDI clock output on/off	68
Clearing parameter lock data.....	51	Turning control change transmission on/off	68
Parameter locking - Direct input	52	Setting MIDI OUT	69
Turning parameter locking on	52	Setting MIDI command transmitting and receiving	69
Recording knob operations	52	Setting MIDI program changes transmitting and receiving	70
Parameter locking - Real-time input 53			
Inputting in real time (parameter recording)	53		
Undoing the real-time recording just captured	53		
Sequence effects	54		

Contents

Setting the channel for transmitting and receiving program changes	70
Exporting/importing user data	71
Connecting - Exporting/importing to/from a PC/Mac	71
Connecting - Exporting/importing to/from another Texture Lab	71
Exporting a single pattern	72
Importing a single pattern	72
Backing up all user data at once	73
Restoring (importing) user data	74
System settings	75
Setting the battery type	75
Setting the automatic power down function.....	75
Setting the headphone gain	76
Setting the master tuning	76
Setting knob movement behavior	77
Restoring to factory default settings (factory reset)	78
Checking the system versions	78
Updating the firmware	79
Error codes.....	80
Appendix	81
Figure1. Sound architecture.....	81

Names of parts

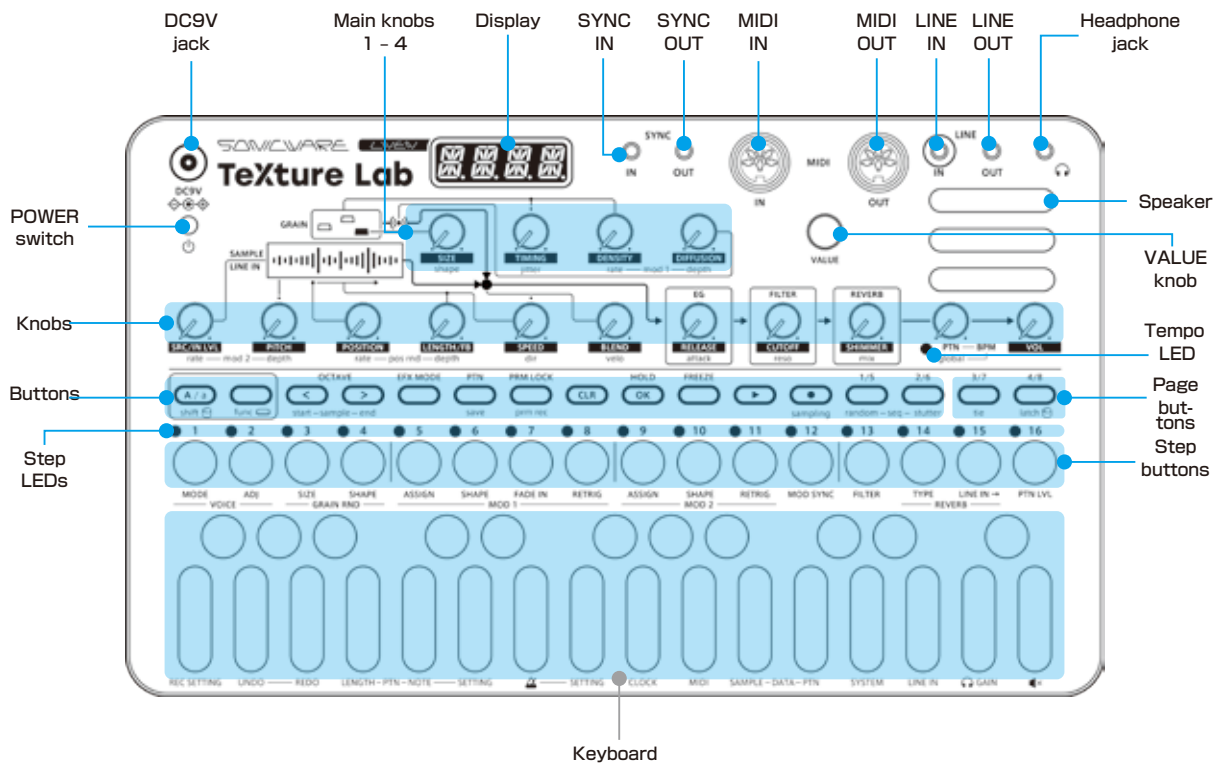

Connection example

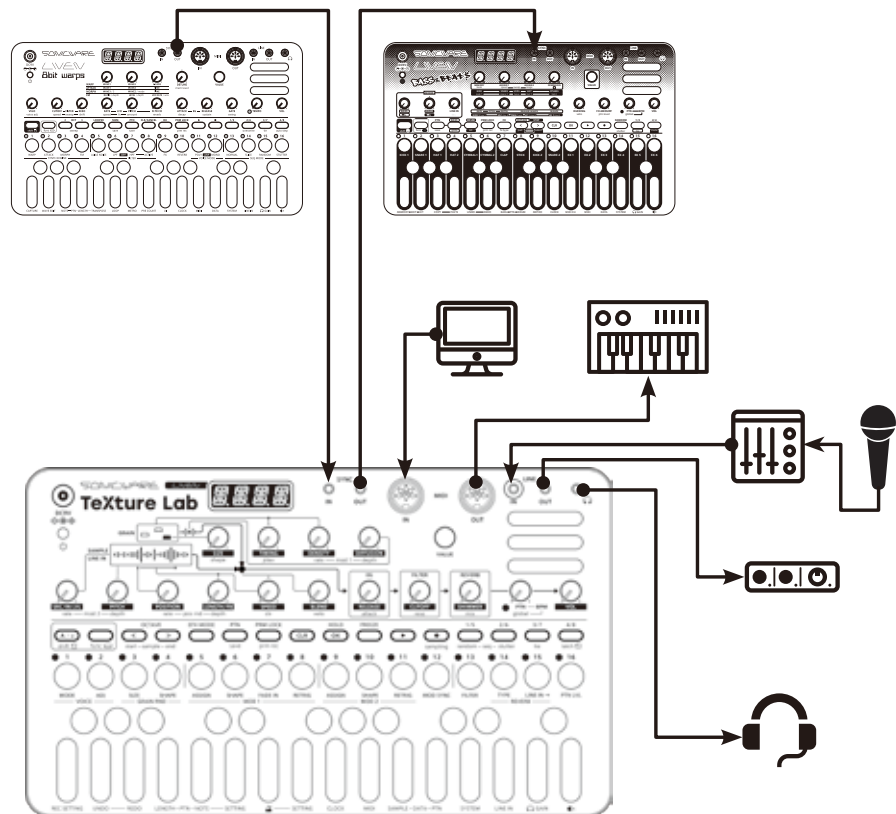

Note: Use connection cables that are 3 m or shorter.

Starting up and shutting down

Preparing a power supply

AC adapter (sold separately)

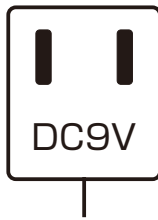

or

6 AA batteries

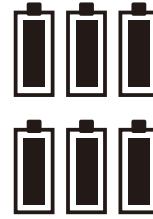

Only use AC adapters that conform to the specifications. Using an AC adapter with different specifications could cause damage.

AC adapter specifications*

Voltage: 9V output
Current: 1A or higher
Connector: EIAJ-03 compliant
(1.7mm inner diameter,
4.75mm outer diameter)

Polarity: center+

*Equivalent to Korg Volca KA350 adapter

BT.LO will appear on the display if the remaining battery charge is low. Replace the batteries immediately.



When using nickel-metal hydride batteries or lithium batteries, change the battery setting.

(→ P.75)

Starting up

- 1 Press and hold the POWER switch until T.LAB (LIVEN Texture Lab) appears on the display.

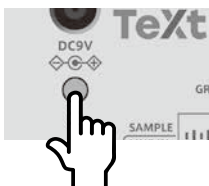

Turning the unit off

- 1 Press and hold the POWER switch until the display turns off.



Recently made changes will be lost when the unit is turned off. Save the changes if necessary.

Basic operations

This section explains basic operations.

Adjusting the overall volume

The volume from the speaker, headphones and the LINE OUT can be adjusted.



Volume
0 - 127
This can be adjusted from $-\infty$ to +6 dB with 0 dB as the middle value (63-64).

Turning on/off the speaker

The built-in speaker can be turned off manually if you want to mute it without connecting headphones (when only using the LINE OUT, for example).





Speaker	
MUTE	Speaker off
SPK	Speaker on

Basic operations

Using the func button

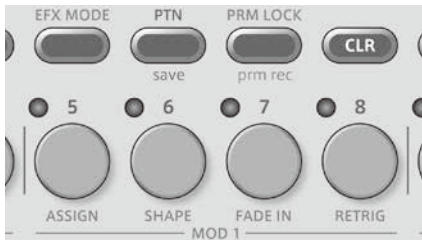
Some Texture Lab buttons have two functions.



In the example above, the secondary functions of the  and  buttons are “save” and “SHAPE” .

Pressing these buttons while pressing the  button will activate their secondary functions.

In this manual, operations while pressing the  button will be shown as follows.



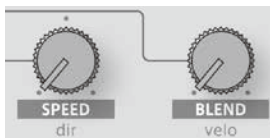

Using the shift button

Many Texture Lab knobs have both **uppercase** and **lowercase** names.







Turning a knob alone will adjust the uppercase parameter.

Turning the knob while pressing the  button will adjust the lowercase parameter.

In this manual, operations while pressing the  button will be shown as follows.



Using the shift button hold function

By pressing the  button while pressing the  button, the  button hold function can be activated. (The button lights orange.) When the hold function is activated, lowercase parameters can be adjusted without pressing the  button.

Press the  button again to deactivate the hold function.

Pattern overview

Pattern overview

A **pattern** contains both sound settings and sequences (performance data). With lengths of 1-8 bars, patterns can be used as the smallest units in making songs.

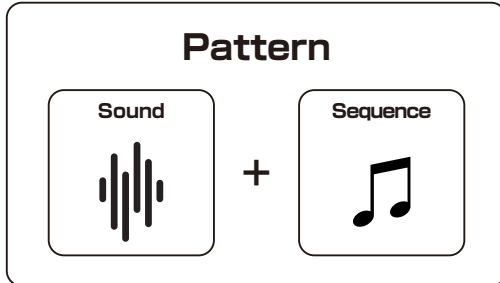

Patterns and banks

16 patterns can be stored together in a single **bank**. The LIVEN Texture Lab has 8 banks enabling 128 patterns to be saved in total.

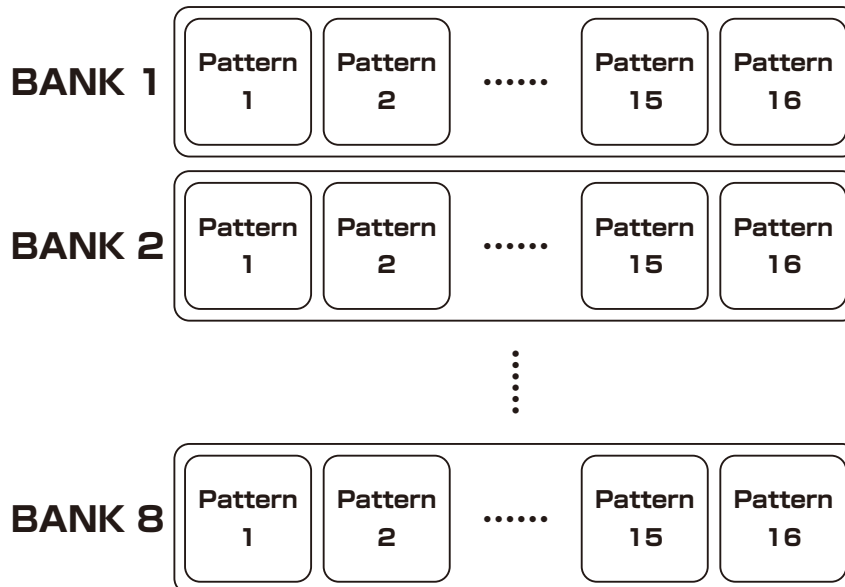

- BANK 1 contains present patterns. Following the instructions on the next page, try playing them.
-

Basic pattern operation

Selecting patterns

1 Press .

2 Press $\frac{1}{5}$ - $\frac{4}{8}$.

→ This selects a pattern.

(STEP 1 for pattern 1... STEP 16 for pattern 16)

Playing patterns





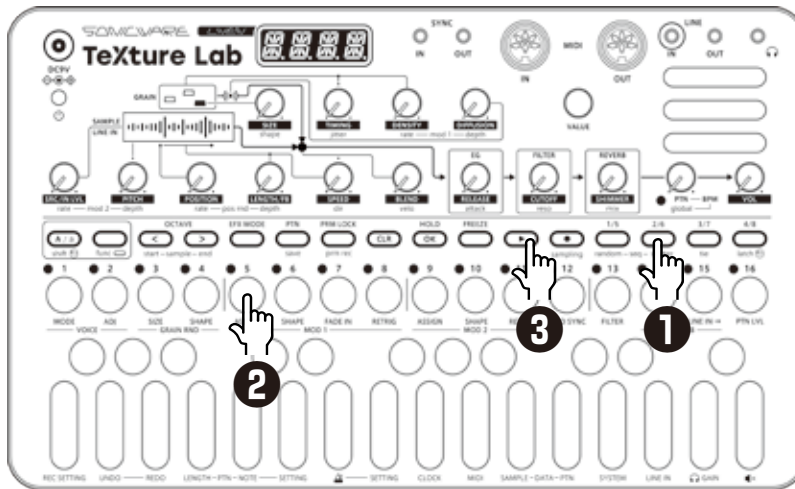



3 Press .

Press it again to stop.





Selecting pattern 17 and higher

Press $\frac{1}{5}$, $\frac{2}{6}$, $\frac{3}{7}$ and $\frac{4}{8}$ after procedure 1 to change the bank, enabling selection of pattern 17 and higher.

	Bank 1		Bank5
	Bank2		Bank6
	Bank3		Bank7
	Bank4		Bank8



- If a different pattern is selected during pattern playback, it will be readied but will not start playing immediately. Playback will switch to the selected pattern after the playing pattern completes.
- After pressing  ,  VALUE can also be used to select patterns.

Basic pattern operation

Changing the tempo



PTN - BPM
40 - 250
When the tempo is shown on the display, the  VALUE knob can be turned to change it in 0.1-beat increments.

Reloading patterns

1 Press .







2 Press .

This is useful for restoring sounds to their original states during live performances, for example.



Pattern chain playback



Selecting multiple patterns and playing them in order (chain playback)

- 1 Press  twice (lights orange).
- 2 Press  - .
Select patterns in the order that you want them to play.
Press  -  again to deselect.
- 3 Press .
The patterns will play in the selected order.



- Press  again to end chain playback.
- Stutter mode (→ P.55) cannot be used during chain playback.

Looping chain playback

- 1 Press  +  multiple times to select CN.LP (**ChaiN LooP**).
- 2 Turn  to select LOOP.

CN.LP

VALUE

Chain Loop	
OFF	After the last pattern has played, that pattern will continue playing in a loop.
LOOP	After the last pattern has played, the chain will continue looping from the first pattern.

Performing with the keyboard and voice modes

Performing



- 1 Play the keyboard.



Holding keyboard notes

- 1 Press  + keys to hold them.



- Press the same key again to stop holding it.
 - Press  +  to stop holding all keys.
-

Changing the velocity



The velocity value used when playing keys can be set.















 + 
shift + velo

Velocity
0-127
The higher the value, the louder the notes will be played.

Performing with the keyboard and voice modes

Changing the octave range

- 1 Press  / .
This lowers/raises the range by an octave.

		+3 octaves
		+2 octaves
		+1 octave
		
		- 1 octave
		- 2 octaves
		- 3 octaves

Changing the voice mode

- 1 Press  + .
This selects the voice mode

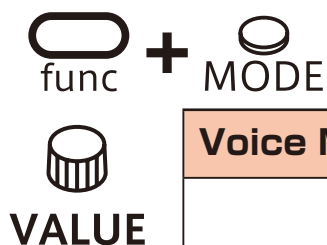



Voice Mode		
<i>POLY</i>	Polyphonic	Up to 4 voices can be output simultaneously in this mode. (Internal sequencer records up to 3 voices of polyphony)
<i>MONO</i>	Monophonic	In this single voice mode, each note retriggers the sound.
<i>LGT</i>	Legato	In this single voice mode, notes do not retrigger the sound.
<i>ARP</i>	Arpeggiator	Pressed keyboard keys are played one at a time in this mode.

Performing with the keyboard and voice modes

Changing the glide (in MONO/LEGATO mode)

1 Press  + .

2 Use  VALUE to set the speed.

 + 
func + ADJ

VALUE

Glide
0 - 127
The time can be changed in a range of 0 - 10000 ms.









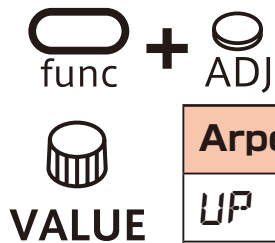



Performing with the keyboard and voice modes

Changing the arpeggiator type (in ARP mode)

1 Press  + .

2 Use  VALUE to select the arpeggiator type.



Arpeggiator		
<i>UP</i>	UP	
<i>DOWN</i>	DOWN	
<i>U.D</i>	UP DOWN	
<i>DU</i>	DOWN UP	
<i>U&D</i>	UP & DOWN	
<i>DU&U</i>	DOWN & UP	
<i>RNDM</i>	RANDOM	
<i>UP+1</i>	UP +1	
<i>UP+2</i>	UP +2	
<i>DN-1</i>	DOWN - 1	
<i>DN-2</i>	DOWN - 2	
<i>PO</i>	PLAY ORDER	 Notes are sounded in the order played on the keyboard

Granular synthesizer

A granular synthesizer divides sampled sounds into small grains (sections) and reproduces those grains with various timings. This synthesis method constructs sounds anew by changing the playback directions, sizes, speeds, pitches and other characteristics of each of those grains in real time.



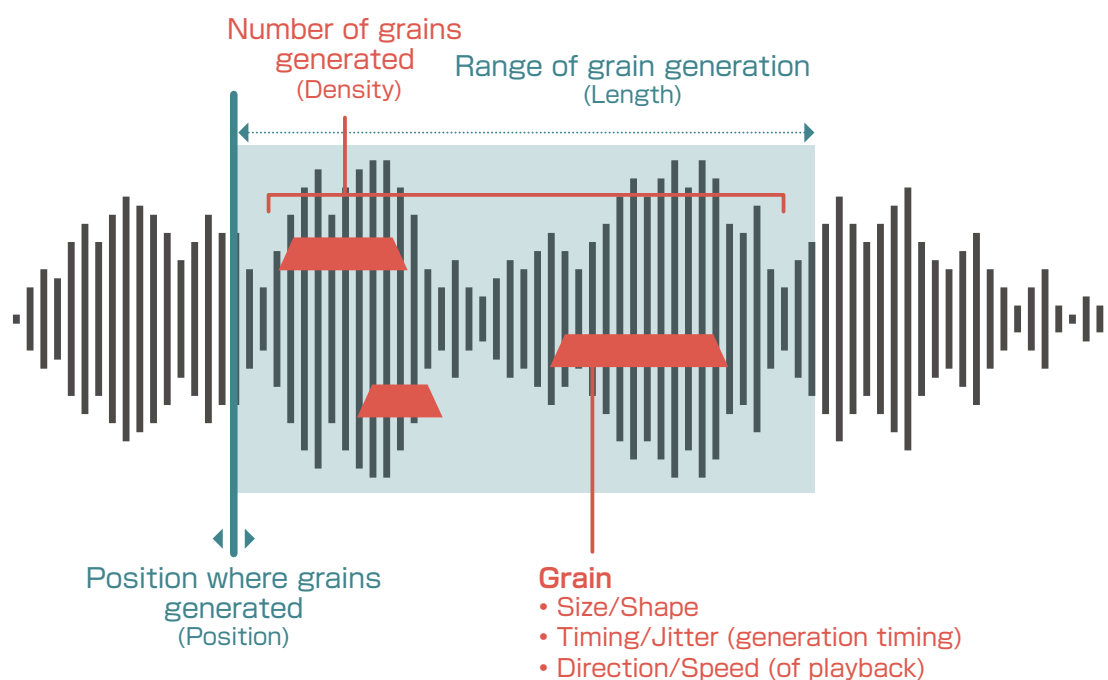

Sounds that are reconstructed from source samples using granular synthesis are good as textural pads used in ambient music and other genres. Moreover, granular processing of drums and other sounds with strong rhythmical attacks can create new rhythm sounds that seem to be constructed with complex delays.

Using Texture Lab simplifies the design of complex sounds by altering the grains with modulators and using the built-in effect.

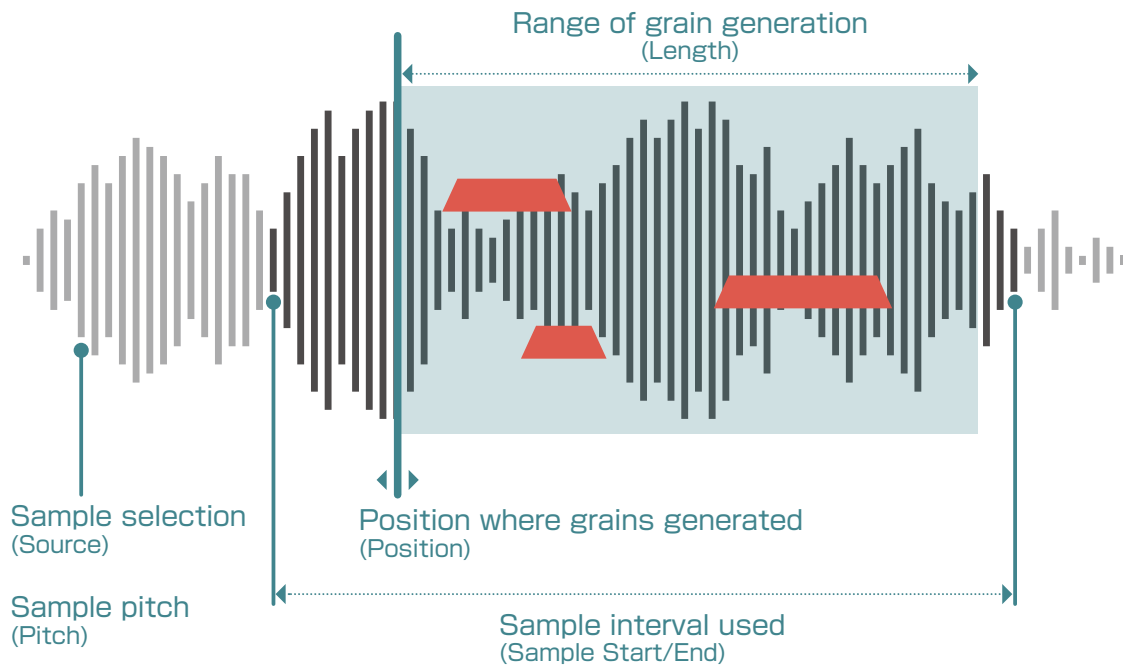





Sample settings



Sample selection	Sample pitch	Position where grains generated in sample	Range of grain generation in sample
 SRC/IN LVL	 PITCH	 POSITION	 LENGTH/FB
Source	Pitch	Position	Length
EPIC - S032	- 24.0 - 24.0	0 - 127	0 - 127
This selects the sampled sound to use for grains. Up to 32 sampled sounds can be saved. See (→ P.31) for details about sampling.	This can be adjusted in a ± 2 octave range.	This can be set from 0 to 6 seconds. By shortening the sample interval, the setting precision can be increased.	This can be set from 0 to 6 seconds. By shortening the sample interval, the setting precision can be increased.

Setting the interval used for the sample

A sample can be up to 6 seconds long, but the interval used can be shortened. Press  +  to set the sample start position or  +  to set the sample end position and use  VALUE to adjust it.

Sample settings

Randomizing grain generation position

The grain generation position can be randomized by using $\text{A/B} + \text{shift}$ + rate-pos rnd to adjust the rate and $\text{A/B} + \text{shift}$ + depth-pos rnd to adjust the depth.

Freezing the grain generation position

The grain generation position can be frozen by pressing FREEZE . This state can be held by pressing $\text{HOLD} + \text{OK}$ while pressing FREEZE .



Grain settings

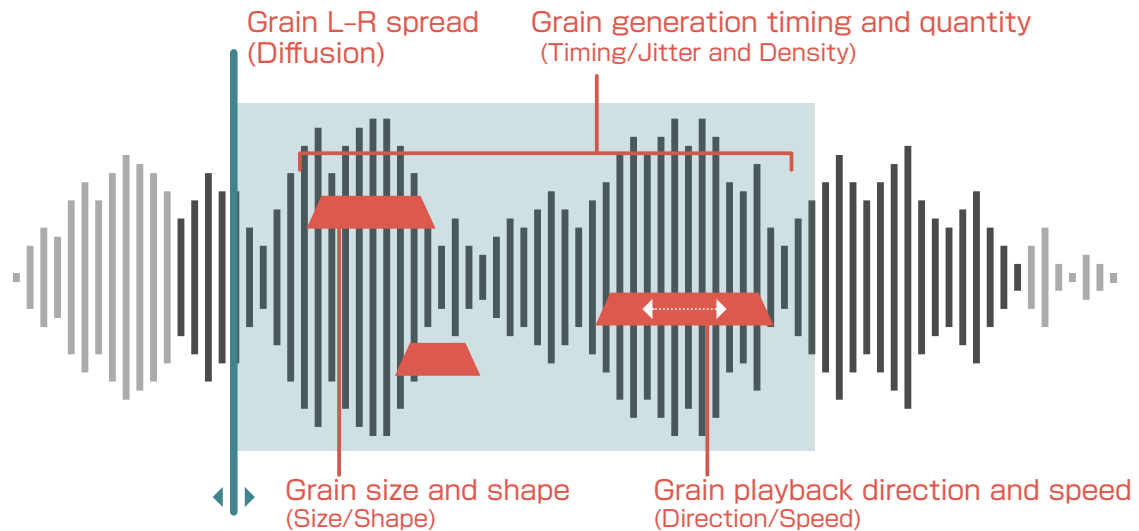



Grain size	Grain generation timing	Number of grains generated	Grain spread
SIZE	TIMING	DENSITY	DIFFUSION
Size	Timing	Density	Diffusion
0 - 127	MO - 62, LUSH, 1/32 - 1/1	0 - 127	0 - 127
Grain size can be set from 2 milliseconds to 1 second.	This sets the grain generation timing. Set to LUSH, the center value, generation timing is the shortest. Turn this left to increase the timing. Turn this right to set generation timing to tempo-synced values.	This can be set from 1 to 64 grains. The maximum density depends on the voice mode. Polyphonic: 16 grains maximum × 4 voices Mono: 32 grains maximum Legato: 64 grains maximum	This spreads the positions of the generated grains to the left and right.
+ shape	+ jitter		
Shape	Jitter		
0 - 127	0 - 127		
This adjusts the shape of the grains.	This sets the amount that grain generation timing fluctuates.	Turning this to the right of center will detune the grains.	

Randomizing grain size and shape

The grain size and shape can be randomized. Press + for the size or + for the shape and use to adjust the amount.

Grain settings

Grain playback speed	Grain scanning and playback directions	
 SPEED	 +  shift + dir	Grain scanning direction . Playback direction
Speed	Direction	-> .-> -> .<- <- .-> <- .<- -> .RN (Random) <- .RN (Random) > < .-> > < .<- > < .> < > < .RN (Random) < > .-> < > .<- < > .< > < > .RN (Random) RND (Random)
- 63 - 63	See the list to the right	
The grain playback speed can be set from 1/4 × to 4 ×. The center is ± 0.	This sets the grain scanning and playback directions. The values in the list to the right can be selected.	

Adjusting the mix of the sample and grain sounds

















When set to 0, the sound will be 100% from the sample. When set to 127, the sound will be 100% from the grains.

 BLEND	Blend
	0 - 127

Modulation

Texture Lab has two modulators that can apply LFOs to various parameters including grain parameters.

Modulation settings

Modulation destination parameter	LFO waveform	Fade-in time	Retriggering
 +   + 	 +   + 	 + 	 +   + 
Assign	LFO Shape	Fade In	Retrigger
See the list on the next page	See the list on the next page	0 - 127	ON, OFF
Use  VALUE to select the parameter to be modulated.	Use  VALUE to select the LFO waveform to use for modulation.	Use  VALUE to set the time until the modulation starts (0 - 8000 milliseconds). MOD 2 does not have this parameter.	This turns retriggering on/off.

Adjusting modulation speed and depth



Modulator 1

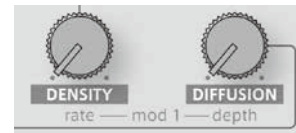

Use  +  rate-mod 1 to adjust the speed.

Use  +  depth-mod 1 to adjust the depth.



Modulator 2

Use  +  rate-mod 2 to adjust the speed.

Use  +  depth-mod 2 to adjust the depth.

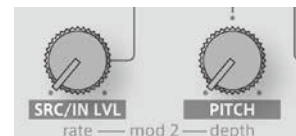

Modulation tempo syncing

Press  +  to turn on/off tempo syncing for modulation.

When on, the modulation speed can be set to 4/1 - 1/32.

 + 

Mod Sync

4/1 - 1/32

Modulation

Modulation destination parameter

Assign (Mod 1/2)	
OFF	Off
SIZE	SIZE
TIME	TIMING
DENS	DENSITY
DIFF	DIFFUSION
PITCH	PITCH
POS	POSITION
LNFB	LENGTH/FB
SPD	SPEED
SHAP	shape
JTTR	jitter
FLCO	FILTER CUTOFF
FLRS	FILTER reso
BLND	BLEND

LFO waveform

Wave (Mod 1/2)	
SINE	Sine wave
SQAR	Square wave
TRI	Triangle wave
SAW	Sawtooth wave
RSAW	Reverse sawtooth wave
RND	Random wave
SRND	Smooth random wave
LOG	Logarithmic wave
RLOG	Reverse logarithmic wave
PL10	10% pulse wave
PL25	25% pulse wave
PL75	75% pulse wave
PL90	90% pulse wave
STP2	Wave with 2 steps
STP3	Wave with 3 steps
STP4	Wave with 4 steps
STP5	Wave with 5 steps
STP6	Wave with 6 steps
STP7	Wave with 7 steps
STP+	Wave with ascending steps
STP-	Wave with descending steps
KEY	Keyboard scale

Envelope generator

Adjusting the attack and release of the granular sound

Use the envelope generator to adjust the attack that affects the beginning of the sound and the release that affects how the sound fades out.

1 Turn  +  attack or  RELEASE .



attack

0 - 127

This changes the attack time in a range of 0 - 5000 ms.



Release

0 - 41

This changes the gate time in a range of 10 - 90%.

42 - 127

This changes the release time in a range of 0 - 5000 ms.

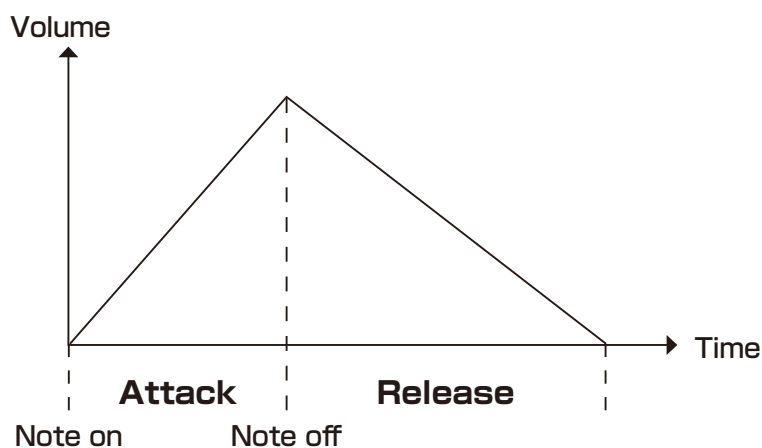

Filters

Changing the filter type

1 Press  +  to select the type.



Filter type	
OFF	No filter used
LPF	Filter that cuts high frequencies
HPF	Filter that cuts low frequencies
BPF	Filter that only allows through frequencies in a specified band

Adjusting the filter cutoff frequency

1 Turn  CUTOFF.



Cutoff
0 - 127
The cutoff frequency can be changed in a range of 70 - 14400 Hz.

Adjusting the filter resonance

1 Turn  +  reso.





Resonance
0 - 127
The resonance can be changed in a range of 0.3 - 10.
For BPF, the bandwidth can be changed in a 0.5 - 3.3 octave range.





Reverb

Texture Lab includes a sublime high-quality shimmer reverb that adds a layer of reverberations an octave above the original pitch.



Adjusting the reverb

- 1 Press  +  to select the effect.
- 2 Use  to adjust the parameter.

VALUE

Reverb type		Reverb shimmer amount	Reverb mix level
 + 		 SHIMMER	 + 
OFF	OFF	---	---
HALL	Hall	Amount	Level
ROOM	Room	Amount	Level
ARENA	Arena	Amount	Level
PLATE	Plate	Amount	Level
TUNNEL	Tunnel	Amount	Level
INF	Infinite	Amount	Level



- Use  +  +  to adjust the reverb send level for LINE IN input.

Deactivating the reverb reset when changing patterns

If you want to play pattern chains without the reverb resetting, set the same reverb type on the patterns you want to chain and set the reverb reset to OFF.

- 1 Press  +  multiple times to select R.RST.



- 2 Select OFF.

Reverb Reset	
OFF	Do not reset the reverb when changing the patterns with the same reverb type.
ON	Reset reverb when the pattern is changed.

Sampling

Overview

Texture Lab can save recorded samples in 32 slots.

Sample slot selection

Turn \odot SRC/IN LVL to select samples.

Sounds can be checked by playing the keys on the keyboard.

(Set \odot BLEND to 0.)

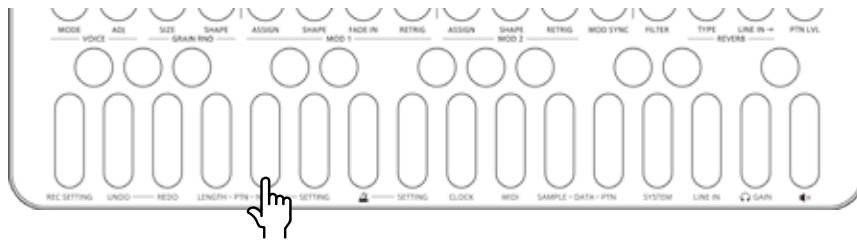

Play this key to hear the sample with its original pitch and length.

(Set \odot POSITION to 0, \odot LENGTH/FB to 127 and \odot_{func} + \odot_{dir} to ->.->.)

Sampling - Recording

- 1 Connect the output of the equipment you want to record to the Texture Lab LINE IN.



- Mics and guitars cannot be connected directly. Use a mixer or other equipment to convert their outputs to line signals.

- 2 Press **func** + **sampling**.
sampling will blink red.
Use the step keys to check the recording level.
(Step 12 indicates -6dB, Step 16 indicates 0dB)

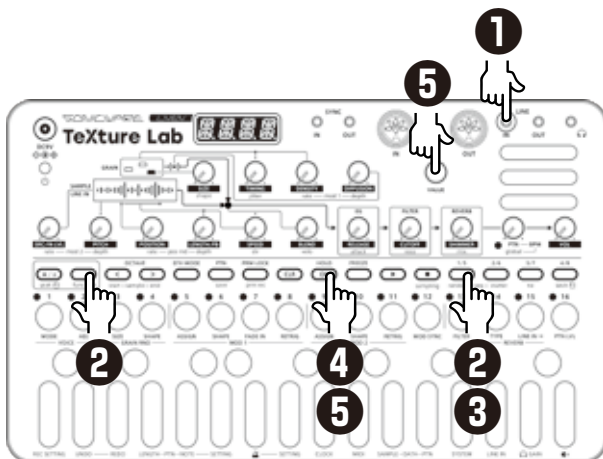

- 3 Press **sampling** again.
sampling will light red and recording will automatically start when a signal is input.



The step keys show the recording progress.
When step 16 lights, recording will stop automatically.

- 4 Press **OK** and use **SRC/IN LVL** to select the slot to save the sample.

You can also use **VALUE** to select the slot.
Before saving the sample, you can audition the sample of the selected slot by playing it with the keyboard.



- Press **STOP** to stop immediately during the recording.
- Press **CLR** to cancel the operation.

- 5 After deciding which slot to save to, press **OK**.

Resampling

Resampling a pattern

- 1 Select a pattern you want to resample.
- 2 Press **func** + **SETTING** to select R.SRC, then switch to PTN using the **VALUE**.



- 3 Press **func** + **sampling** to enter the sampling, and press **OK** to standby for recording. **OK** will light red.

- 4 Press **▶** to start pattern playback, recording starts automatically.

Recording will automatically start by the auto recording function.

The step keys show the recording progress. When step 16 lights, recording will stop automatically.

- 5 Press **OK** and use **SRC/IN LVL** to select the slot to save the sample.

You can also use the **VALUE** to select the slot.

Before saving the sample, you can audition the sample of the selected slot by playing it with the keyboard.



- Press **OK** to stop immediately during the recording.
- Press **CLR** to cancel the operation.

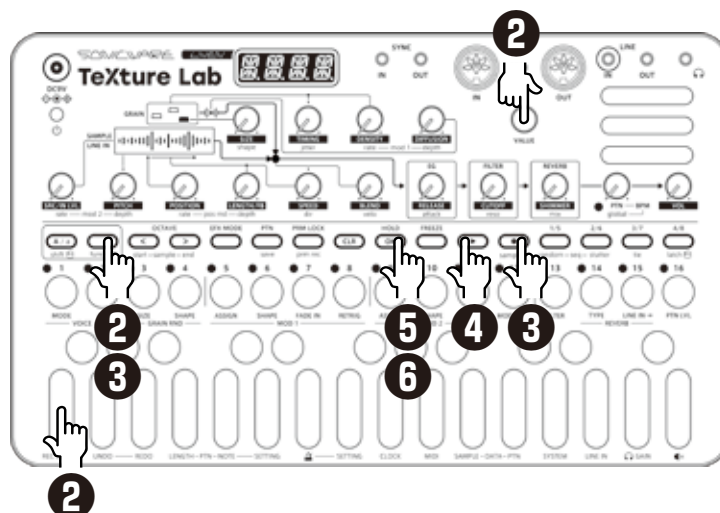

- 6 After deciding which slot to save to, press **OK**.



Sampling settings

The following settings are used for sampling.

Setting auto recording

1 Press  +  to select A.R.LV. 

2 Turn  VALUE .

This can be set to OFF or the input signal level that starts recording automatically (- 60 - - 20 dB).

If auto recording is off, press  when in recording standby to start recording.



- Use func + LINE IN to adjust the LINE IN input gain.
 - After recording completes, the volume of the sample will be normalized automatically.
-

Exporting/importing samples

Recorded samples can be exported to or imported from a PC, Mac or similar device by MIDI. See page 81 for details about connection.

Exporting a single sample

1 Use slot selection to select the sample you want to export.

2 Press  +  multiple times to select S.EXP.



3 Press .



4 Set your PC to receive MIDI data.

5 Press .
This starts sample data transmission.



The step LEDs will show the progress. When finished, DONE will appear on the display.

Importing a single sample

1 Use slot selection to select the slot you want to import to.

2 Press  +  multiple times to select S.IMP.



3 Press .

4 Start transmitting data from the transmitting device.



5 After receiving data has completed, press  to save it.

Renaming samples



Renaming samples

1 Select the sample you want to rename.

2 Press  +  to select S.N.E.D.



3 Press .

4 Use  and  to move the cursor left and right, and turn  VALUE to select characters.

5 Press .

This completes the setting.
DONE will appear on the display.



-
- Press  during a procedure to cancel it.
-

LINE IN settings

Changing the gain

1 Press  +  to select GAIN.

GAIN

2 Turn  VALUE to change the gain.

VALUE

Gain
MUTE - 127

Setting mono/stereo

1 Press  +  to select MONO.

MONO

2 Turn  VALUE to switch between ON and OFF.

VALUE

Monophonic	
ON	Mono
OFF	Stereo

Granular effect mode

Texture Lab has an effect mode (**EFX MODE**) that can be used to apply granular synthesis to external input in real time.

Connect other LIVEN synthesizers and samplers, for example, and use this mode to apply granular effects to their sounds.

Switching to effect mode

- 1 Press .

Connecting a source to the LINE IN and adjusting its level





- 1 Connect the output of the equipment you want to use the effect on to the Texture Lab LINE IN.





- 2 Turn  SRC/IN LVL to adjust the line input level.



- Mics and guitars cannot be connected directly. Use a mixer or other equipment to convert their outputs to line signals.
 - Set it to mono or stereo. (→ P.37)
-

Parameters that are different in effect mode

Effect buffer time	Effect feedback	Grain playback direction	
 POSITION	 LENGTH/FB	 +  shift dir	Grain playback direction ---> <--- RND (Random)
Delay Time	Feedback	Direction	
0 - 127	0 - 127	See the list to the right	
This sets the delay time before generation of the first grain. This can be set from 4 to 5,944 milliseconds.	This sets the amount of feedback for the effect.	This sets the grain playback direction. The values in the list to the right can be selected.	

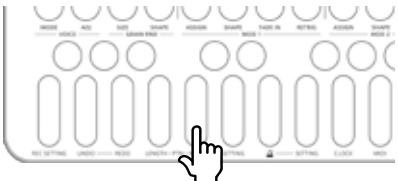
Effect Note	
 +  func + MODE - VOICE	 +  func + ADJ - VOICE
EFX Note	Glide
ON, OFF	0 ~ 127
When turned ON, the pitch changes to the pitch corresponding to the key pressed based on the low C key.	 <p>The time can be changed in a range of 0 - 10000 ms.</p>



- EFX will appear on the display for the following parameters, which are disabled.
SPEED, EG - RELEASE/attack

Freezing line input

Press  to freeze the six seconds of line input signal stored in the buffer.

This state can be held by pressing  while pressing .



Step sequencer overview

Overview

The Texture Lab step sequencer can play **multiple steps** in order (a sequence) with performance and parameter data.



Steps contain **note data** and **parameter data**.

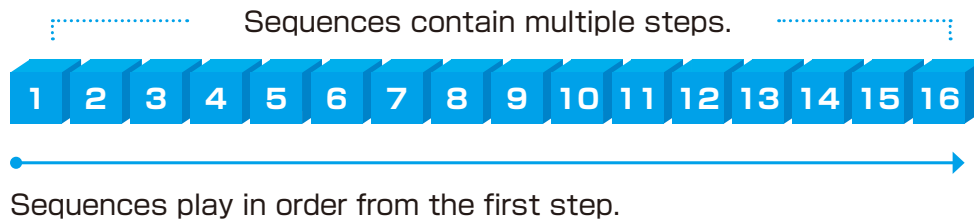

Texture Lab step sequencer features

The sequencer in the Texture Lab has the following features.

Three input methods

Step recording

Record notes to each step with the sequencer stopped

Real-time recording

Record notes to steps by playing the keyboard

Direct recording

Record notes to steps directly during sequencer playback

Flexible sequencing

Sequences with up to 128 steps

The number of steps can be set from 1 – 128 as desired for each track

Support for various note lengths

The length of each step can be set from 1/32nd note to 1 bar.

Creating sequences - Settings

Setting the note length of one step

1 Press  + .

2 Use  VALUE to select the note length.

VALUE

Note	
1/1	Whole note
1/2	Half note
1/.4	Dotted quarter note
1/4	Quarter note
1/.8	Dotted 8th note
1/2T	Half note triplet
1/8	8th note
1/.16	Dotted 16th note
1/4T	Quarter note triplet
1/16	16th note
1/32	32nd note

Changing the sequence length

1 Press  + .

2 Use  VALUE to set the sequence length.



VALUE

Length
1 - 128 (steps)

Creating sequences – Step recording

Using step recording, sequences can be created carefully while playback is stopped.

Basic operations

- 1** When stopped, press  (lights red).
- 2** Press $\circ^1 - \circ^{16}$ at the step where you want to input a note.
The LED for the current step will blink. The LEDs for steps that already have notes will light.
- 3** Play a note on the keyboard to input it at the step.
Press the same note again on the keyboard to remove it from the step.
Repeat steps 2 – 3 to create the sequence.
- 4** Press  to end step recording.

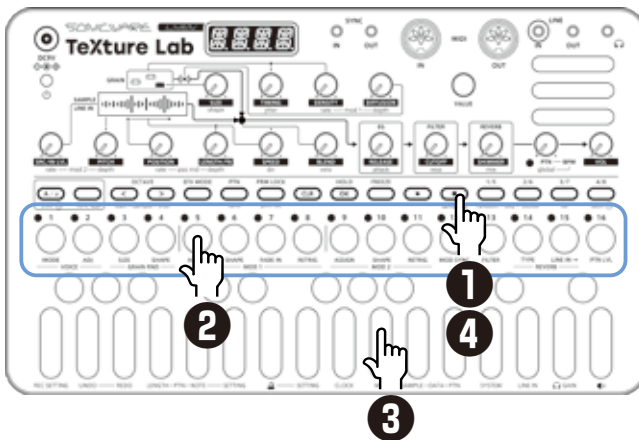

Creating sequences - Step recording

Selecting steps 17 and higher

After procedure number one, press $\frac{1}{5}$, $\frac{2}{6}$, $\frac{3}{7}$ and $\frac{4}{8}$ to select steps 17 and higher.

To select steps 1-16, press the $\frac{1}{5}$ button.



To select steps 17-32, press the $\frac{2}{6}$ button.



To select steps 33-48, press the $\frac{3}{7}$ button.



To select steps 49-64, press the $\frac{4}{8}$ button.



To select steps 65-80, press the $\frac{1}{5}$ button twice.



To select steps 81-96, press the $\frac{2}{6}$ button twice.



To select steps 97-112, press the $\frac{3}{7}$ button twice.





To select steps 113-128, press the $\frac{4}{8}$ button twice.



- In procedure 2, pressing $\frac{1}{5}$ - $\frac{4}{8}$ will cause the stored note to sound continuously. This is by design.
- $\frac{1}{5}$ VALUE can also be used to move between steps.
- Page buttons are enabled or disabled according to the length of the sequence.

Creating sequences - Step recording

Clearing steps

- 1 Press  +  - .
During step recording, only the note information for that step will be cleared.

Automatically advancing steps during step recording (Auto Step mode)

In step recording mode, the step can be advanced automatically each time a key of the keyboard is pressed.

- 1 Press  +  multiple times to select A.STP.



- 2 Turn this mode on/off.





Creating sequences - Step recording

Tied-notes (long sounds) can be input with the Texture Lab.

Enabling tied-note (long sound) input

- 1 Press  +  .
The button will light red, and tied-note input will be enabled.



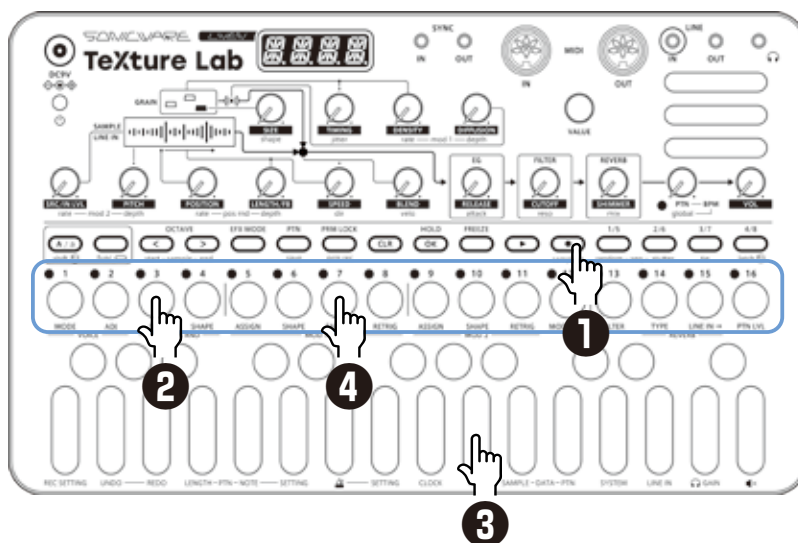

Inputting tied-notes (long sounds)

- 1 When stopped, press  (lights red) to start step recording.
- 2 Press  -  at the step where you want to start note input.
- 3 Press and hold a key on the keyboard.
- 4 Press  -  at the step where you want to stop the note.
This inputs a tied-note from the starting step to the stopping step.



In the example above, a note (A) is input that starts on step 3 and ends on step 7.





- By pressing  ,  ,  and  during procedure 4, tied-notes that span pages can be input.



Creating sequences - Real-time recording

Sequences can be created in real time while playing the keyboard.

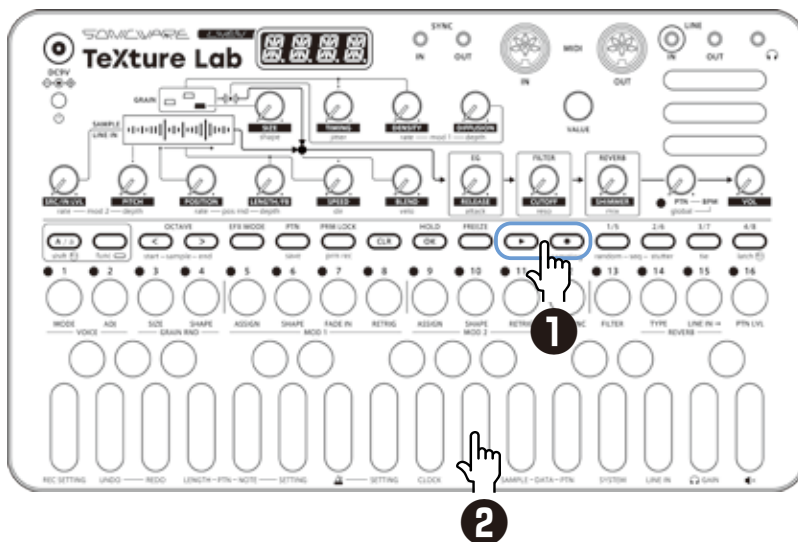

Basic operations

- 1 After pressing , press .
- 2 The pattern will start playing, so play the keyboard when you want to input notes.





- By pressing  +  to enable the input of tied-notes, long notes that span steps can be input.

Undoing the real-time recording just captured

- 1 Press  to disable recording.
- 2 Press  + . The state before recording will be restored.



- Only the immediately previous state can be restored.
- Press  +  to cancel undoing.

Creating sequences - Real-time recording

Turning on/off the metronome

1 Press  +  to switch ON/OFF.



Adjusting the metronome volume

1 Press  +  to select VOL.



2 Use  VALUE to adjust the metronome volume.

 VALUE	Metronome
	0 - 15

Setting a pre-count

1 Press  +  to select PR.CT.



2 Use  VALUE to change the pre-count.

 VALUE	Metronome
	OFF, 1 - 8



- When a pre-count is set, recording and playback will start after the pre-count.
-

Creating sequences - Direct recording

With direct recording, notes can be input on steps directly when both stopped and playing back.

This is particularly suitable for building up sequences while performing by directly inputting notes during playback.

Basic operations

- 1 Press and hold $\circ^1 - \circ^{16}$ for the position where you want to input a note
- 2 Play a note on the keyboard to input it at the step. Notes can also be input if procedures 1 and 2 are done in reverse order.

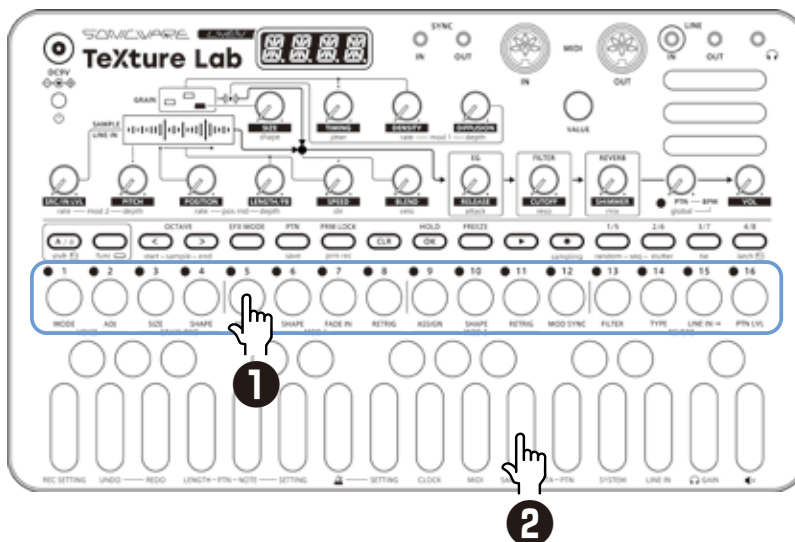

Creating sequences - Direct recording



- After procedure number one, press $\frac{1}{5}$ 、 $\frac{2}{6}$ 、 $\frac{3}{7}$ and $\frac{4}{8}$ to select steps 17 and higher.

To select steps 1-16, press the $\frac{1}{5}$ button.



To select steps 17-32, press the $\frac{2}{6}$ button.



To select steps 33-48, press the $\frac{3}{7}$ button.



To select steps 49-64, press the $\frac{4}{8}$ button.



To select steps 65-80, press the $\frac{1}{5}$ button twice.



To select steps 81-96, press the $\frac{2}{6}$ button twice.



To select steps 97-112, press the $\frac{3}{7}$ button twice.



To select steps 113-128, press the $\frac{4}{8}$ button twice.



- During playback, pressing $\frac{1}{5}$ 、 $\frac{2}{6}$ 、 $\frac{3}{7}$ and $\frac{4}{8}$ will lock the page shown.

Press  to unlock the page.

Creating sequences - settings

Setting the swing

- 1 Press  +  multiple times to select SWNG.



- 2 Adjust the swing with  .
Every even step (2nd, 4th, 6th, etc.) will be delayed.



Transposing

- 1 Press  +  multiple times to select TRPS.
Change the pitch with  .



VALUE

Transpose
-12 ~ +12 (in semitone)

Parameter locking

The Texture Lab has a **parameter locking** function that can record knob operations to steps.

This allows sounds to be changed over time and is useful for creating patterns with great expressiveness.

Parameter locking data can be input in the following two ways.

Direct input

Turn knobs while pressing $\text{1} - \text{16}$ in this fundamental method of direct input.



Real-time input

Record the operation of knobs during playback in real-time in this method.

Basic parameter locking operations

Turning parameter locking on

- 1 Press PRM LOCK .
Pressing PRM LOCK cycles through the following states.

PRM LOCK 	Parameter locking off	Parameters do not change automatically
PRM LOCK 	Parameter locking on	Parameters change automatically based on parameter lock data

Clearing parameter lock data



- 1 Press $\text{CLR} + \text{PRM LOCK}$.
This clears parameter lock data.

Parameter locking – Direct input



Turning parameter locking on

1 Press  (lights green).

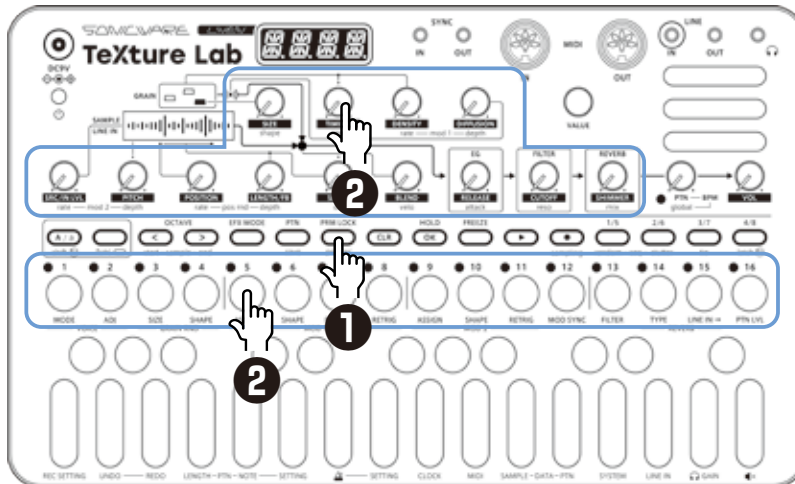

Recording knob operations

2 While pressing  - , turn  knobs.



- By pressing  -  before procedure 2, pages with steps 17 and higher can be selected.
- Parameter locking cannot be used on SRC/IN LVL, PTN BPM, global BPM and VOL.



- The probability of notes sounding can be set from 25 - 100% independently for each step with  VALUE while pressing .

Parameter locking – Real-time input

Inputting in real time (parameter recording)

- 1 Press $\text{func} + \text{prm rec}$ (lights red).
- 2 Press play to play the pattern.
- 3 Turn knobs and record the changes.
- 4 Press PRM LOCK , making it light green, to end real-time input.

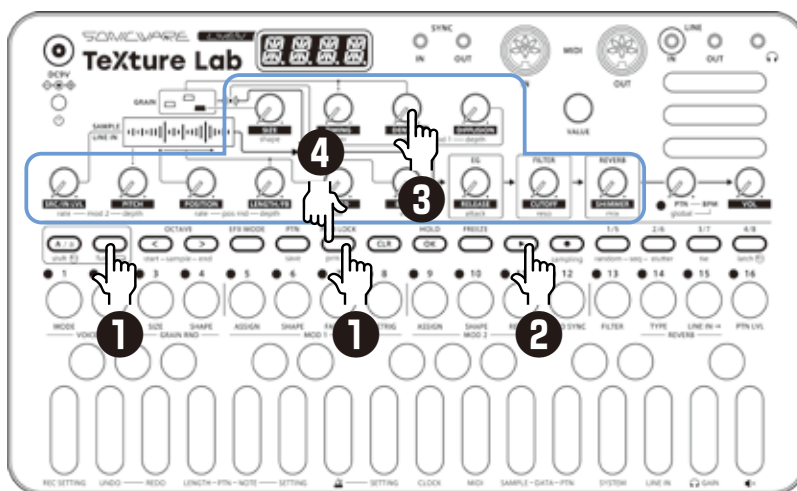

Undoing the real-time recording just captured

- 1 Press PRM LOCK to disable recording.
- 2 Press $\text{func} + \text{UNDO}$.
The state before recording will be restored.



- Only the immediately previous state can be restored.
- Press $\text{func} + \text{REDO}$ to cancel undoing.

Sequence effects

The Texture Lab has sequence effect functions, including **Random** that can randomize phrases, and **Stutter** that repeats playback of pressed steps.

Random

1 Press  + .

When this is on, a randomized sequence will be played back

Press  +  again to turn the random function off.

Random settings

The smallest unit used for randomization during random playback can be set (for example, 1 step or 4 steps).

1 Press  + ,
and use  to adjust.



VALUE



Random step unit
OFF, 1, 2, 4, 8, 16 (steps)
If set to OFF, randomization will not occur even if the random playback function is on.

The random on/off setting is saved with the pattern.

Sequence effects

Stutter

1 Press  +  .
Turning this on enables stutter mode.

2 Press  -  .
Only the pressed steps will be played.







Press  +  again to turn stutter mode off.

Deleting sequences



Clearing steps

- 1 Press  +  ~ .
The note and parameter lock data from that step will be cleared.



- While pressing , steps that have parameter lock data blink red.
 - When recording notes ( lit red), only note data will be cleared.
 - When parameter recording ( lit red), only parameter lock data will be cleared.
 - Normally, when  and  buttons are lit red, both note and parameter data will be cleared.
-

Clearing all note data in a sequence

- 1 Press  +  for the pattern with the sequence to be cleared.

- 2 Use  to select NOTE, and press .



This clears all notes on all steps of the sequence.

Restoring only the sound to the last saved state

- 1 Press  +  for the pattern with the sound to be restored.

- 2 Turn  to select SND, and press .



Pattern saving

Sequences can be saved as patterns.

Saving patterns



1 Press  + .



2 Press .
DONE will appear, and it will be saved.





Changing the save destination or **copying the pattern**

1 Press  + .

2 Use , ,  and  to select the save destination bank.

3  -  to select the save destination pattern.
DONE will appear, and it will be saved.





- In procedure 2,  VALUE can also be used to select the save destination (execute with .
- Press  during a procedure to cancel it.

Initializing patterns

1 Select the pattern to be initialized.
(→ P.14)

2 Press  + .

3 Use  VALUE to select ALL, then press .
Pattern settings along with note and parameter lock data will all be cleared.



4 Save the pattern.



Pattern renaming

Renaming patterns

- 1** Press  +  to select P.N.ED (pattern name editing).



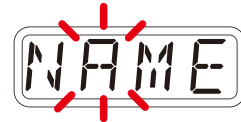

- 2** Use  VALUE to select the pattern for renaming, and press .

- 3** Use  and  to move the cursor left and right, and turn  VALUE to select characters.



Cursor position blinks

- 4** Press .
- This saves the name and returns to pattern selection.
- To rename other patterns, repeat from procedure 2.
- To end renaming, press .



Tempo overview

The Texture Lab has two BPM modes.

Pattern BPM mode

Whenever a different pattern is selected, the BPM is reset using the tempo saved in that pattern.

Global BPM mode

The current global BPM value will continue to be used even when a different pattern is selected.

Select global BPM mode to maintain a consistent tempo during the jam session. Use pattern BPM mode when you want the tempo to change with each pattern.

Setting the BPM mode

1 Press  +  multiple times to select BPM.



2 Use  VALUE to select the BPM mode.



BPM	
BPM mode	
PTN	Pattern BPM mode
GLBL	Global BPM mode

Setting the pattern BPM



1 Turn  PTN — BPM.



Pattern BPM
40 - 250
When the tempo is shown on the display,  VALUE can be turned to change it in 0.1-beat increments.

Tempo overview

Setting the global BPM

1 Press  + .

 +  global - BPM

Global BPM
40 - 250
When the tempo is shown on the display,  VALUE can be turned to change it in 0.1-beat increments.

Clock synchronization with external devices — Clock settings

Overview

The LIVEN has the following synchronization capabilities.

SYNC

Use the SYNC IN/OUT jacks to connect and synchronize with devices that support SYNC (including the Korg Volca series).

MIDI

Use the MIDI IN/OUT jacks to connect and synchronize with devices that support MIDI.

Audio Sync

Use the LINE IN and headphone jacks to connect and synchronize with devices that support Audio Sync (including the Teenage Engineering Pocket Operator series).

When using Audio Sync, the audio exchanged will be mono.

The LIVEN can act as a clock master or receive clock from an external device.

Clock synchronization with external devices — Clock settings

Setting the clock source

When set to INT (internal), the Texture Lab acts as a clock master. When not set to INT, the external device will be treated as the clock master.

1 Press  +  to select SRC.



2 Turn  VALUE to set the clock source.



Clock Source	
INT	Use internal clock of LIVEN Texture Lab
MIDI	Use clock from MIDI IN
SYNC	Use clock from SYNC IN
LINE	Use clock from LINE IN

Setting Audio Sync output

Audio Sync output uses the headphone jack. For this purpose, make the following setting to use Audio Sync output.

1 Press  +  and select A.OUT.



2 Turn  VALUE to select ON.



- The sync signal will be output from the left channel and a mono mix of the audio will be output from the right channel of the headphone jack.

Clock synchronization with external devices — Clock settings

Setting SYNC IN polarity

1 Press  +  and select S.I.P.O.



2 Turn  VALUE to set the polarity.

VALUE

Polarity - Sync In	
FALL	Synchronize with falling of sync signal
RISE	Synchronize with rising of sync signal

Setting SYNC OUT polarity

1 Press  +  and select S.O.P.O.



2 Turn  VALUE to set the polarity.

VALUE

Polarity - Sync In	
FALL	Synchronize with falling of sync signal
RISE	Synchronize with rising of sync signal



- See (→ P.68) for details about setting MIDI clock.

Clock synchronization with external devices — Connection examples

LIVEN as clock master

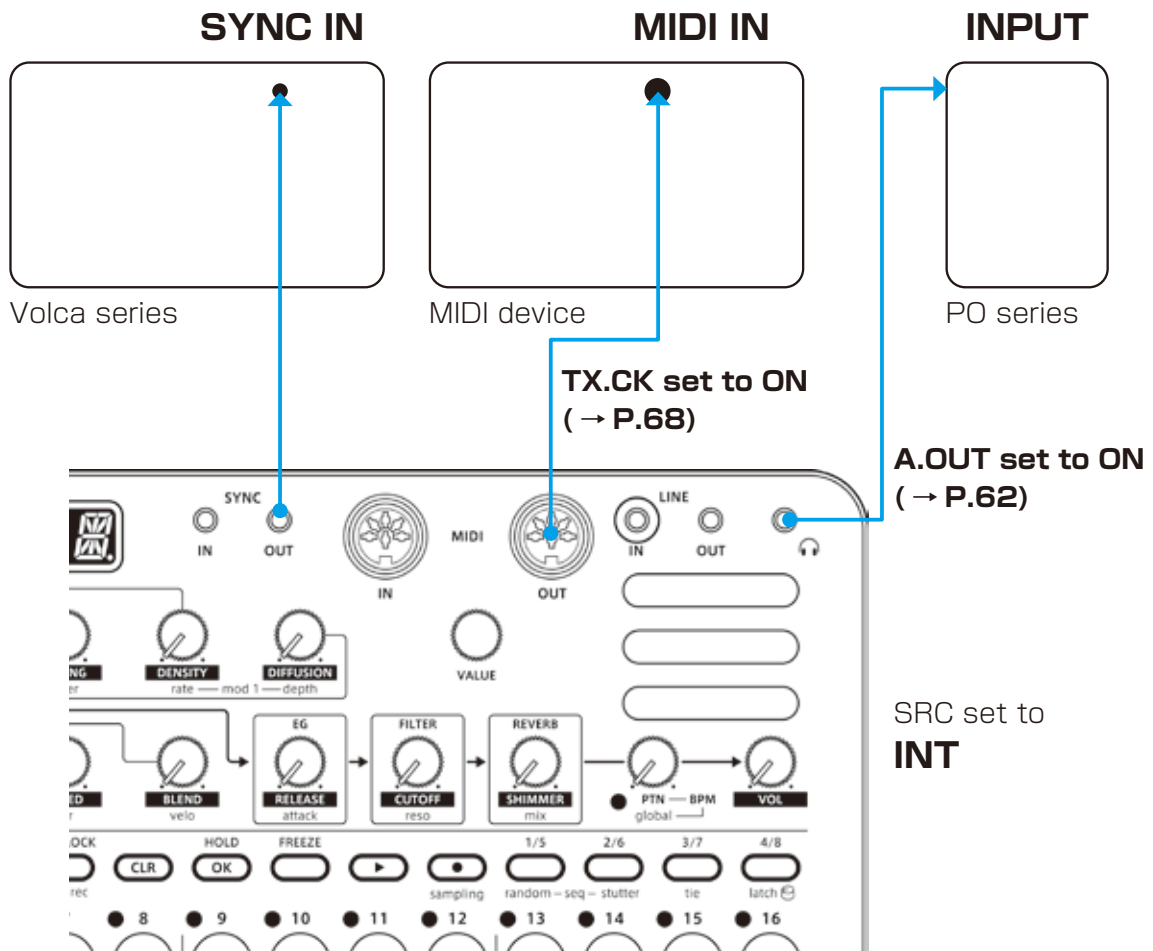

Clock synchronization with external devices — Connection examples

External device as clock master

Make only one device the clock master

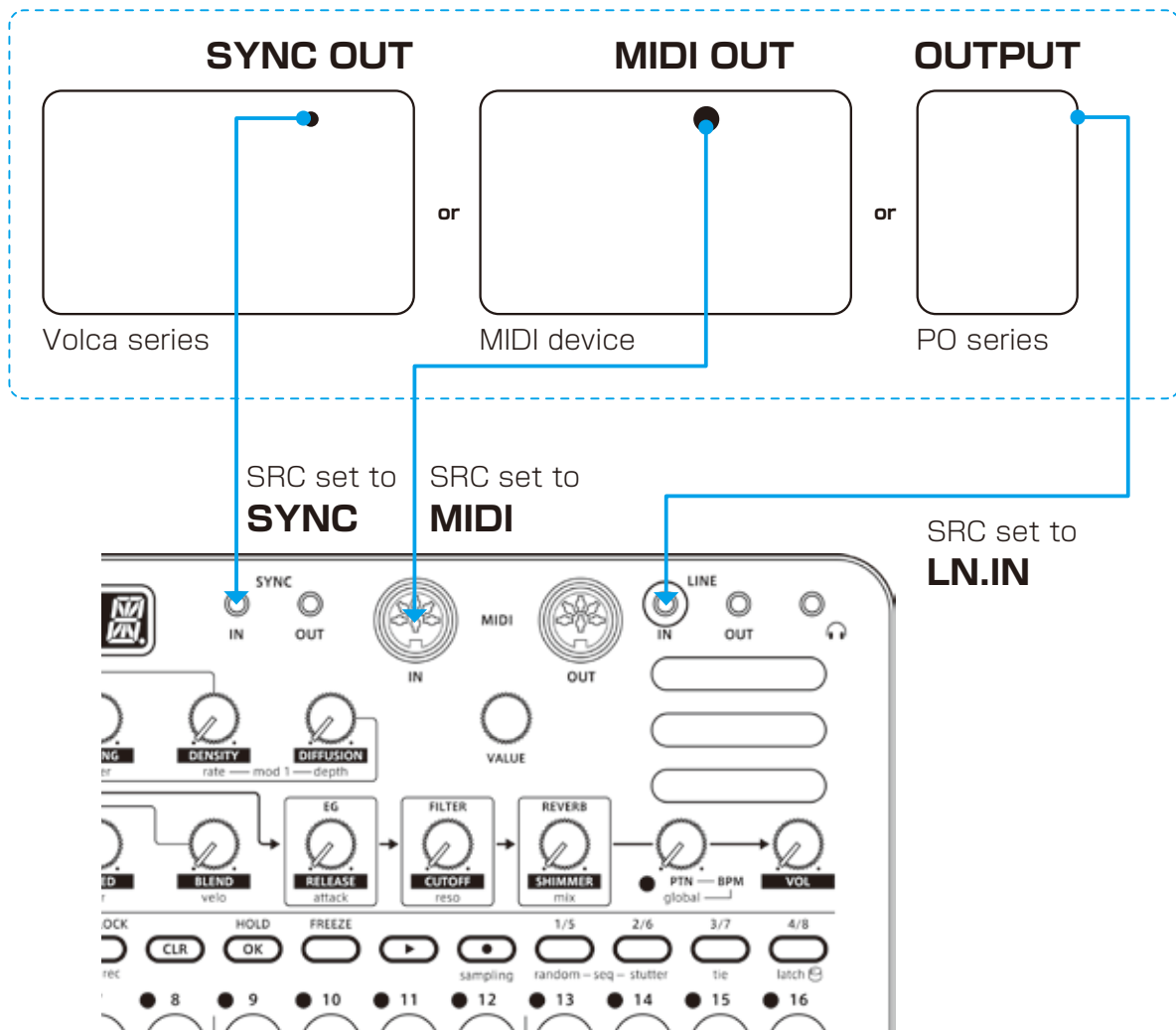

Clock synchronization with external devices — Connection examples

Bridging clock signals to a different connector from an external device acting as the clock master

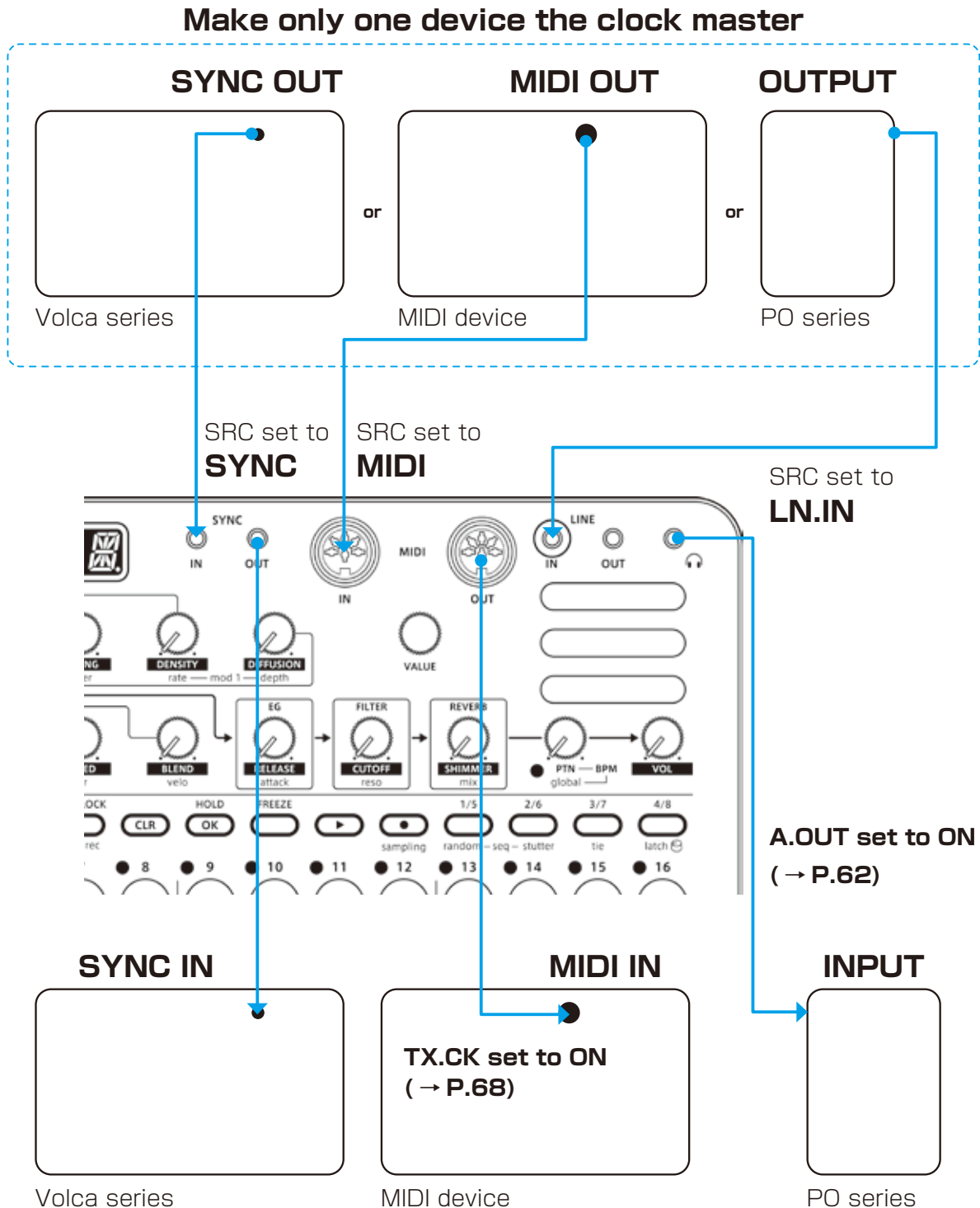

Using the bridging function, it is possible to synchronize devices with different connectors. For example, a Pocket Operator acting as a clock master can be used to synchronize a Volca or MIDI device connected to the LIVEN.

MIDI

Setting channels for receiving MIDI

- 1** Press  +  multiple times to select RX.CH.

RX.CH

- 2** Turn  VALUE to set the channel.



VALUE

MIDI Channel
ALL、CH.01 ~ CH.16、NONE

Setting channels for transmitting MIDI

- 1** Press  +  multiple times to select TX.CH.

TX.CH

- 2** Turn  VALUE to set the channel.

VALUE

MIDI Channel
CH.01 ~ CH.16

MIDI

Turning MIDI clock output on/off

1 Press  +  multiple times to select TX.CK.



2 Turn  VALUE to set it to on/off.

 VALUE	MIDI Clock
	ON, OFF

Turning control change transmission on/off

1 Press  +  multiple times to select TX.CC.



2 Turn  VALUE to set it to on/off.

 VALUE	Control Change
	ON, OFF



- Control change reception is always enabled.
-

MIDI

Setting MIDI OUT

- 1 Press  +  multiple times to select M.OUT.



- 2 Turn  VALUE to set MIDI OUT.



MIDI OUT
OUT, THRU

Setting MIDI command transmitting and receiving

- 1 Press  +  multiple times to select M.CMD.



- 2 Turn  VALUE to set MIDI command transmitting and receiving.



MIDI Commands	
OFF	Neither transmit nor receive
Rx	Only receive
Tx	Only transmit
Rx,Tx	Transmit and receive

MIDI

Setting MIDI program changes transmitting and receiving

- 1 Press  +  multiple times to select M.PC.



- 2 Turn  VALUE to set it to MIDI program changes transmitting and receiving.

VALUE

Program Change	
OFF	Neither transmit nor receive
Rx	Only receive
Tx	Only transmit
Rx,Tx	Transmit and receive

Setting the channel for transmitting and receiving program changes

- 1 Press  +  multiple times to select PC.CH.



- 2 Turn  VALUE to set the program change channel.



VALUE

Program Change - Channel
CH.01 ~ CH.16

Exporting/importing user data

Connecting

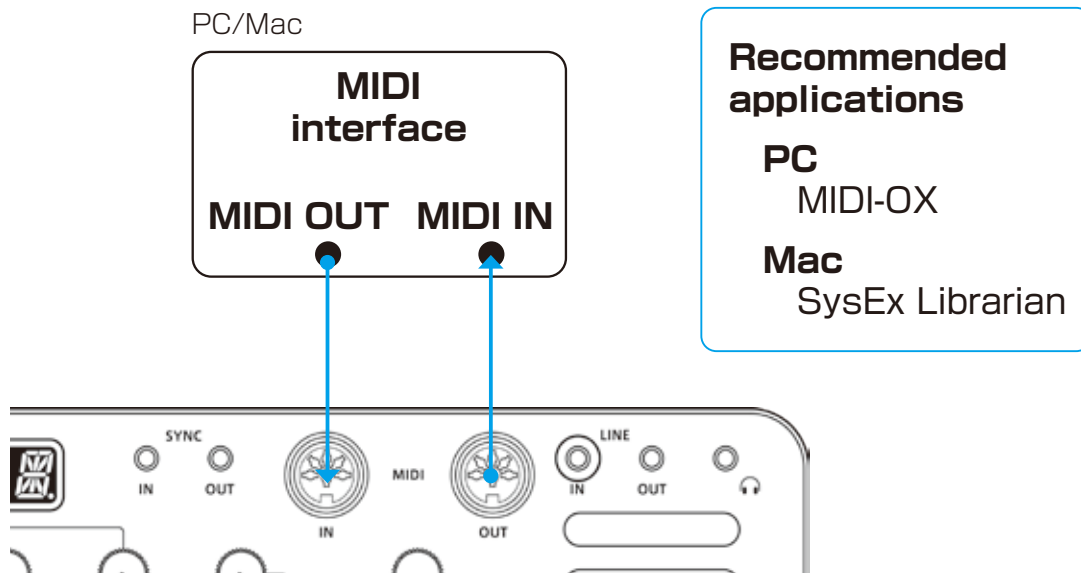
- Exporting/importing to/from a PC/Mac



Connecting

- Exporting/importing to/from another Texture Lab

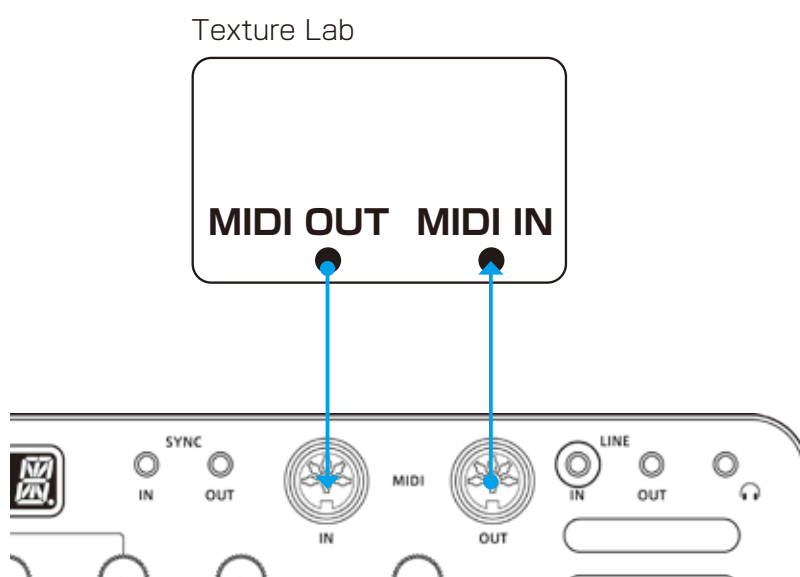

Exporting/importing user data

Exporting a single pattern

1 Select the pattern you want to export. (→ P.14)

2 Press  +  and select P.EXP.



3 Set your PC to receive MIDI data.

4 Press .



-
- Press  to cancel.
-

Importing a single pattern

1 Put the unit into regular mode, and start transmitting data from the transmitting device.



-
- The received pattern will not be saved automatically. Save the pattern as necessary. (→ P.57)
-

Exporting/importing user data

Backing up all user data at once



1 Press  + the **POWER** switch to turn on the Texture Lab.

2 Turn  VALUE to select EXPT.



3 Press .



-
- The step LEDs show the progress. (They light from ① in order. Transmission is complete when ① - ⑥ have all lit.)
 - Press  to cancel.
 - The size of the backup data is 17,164,228 byte.
 - If the size of the data is different, the backup might have failed. If this occurs, before step ③, while pressing , turn  VALUE to increase the transmission interval. (The default value is 0.)
-

Exporting/importing user data

Restoring (importing) user data

1 Press  + the **POWER** switch to turn on the Texture Lab.





2 Turn  VALUE to select IMPT.



3 Press . This makes the unit ready to receive data.
Start exporting from the sending device.

4 When SAVE appears on the display after receiving completes, press  to restore (load) the received data.



-
- The step LEDs show the progress. (They light from  in order. Transmission is complete when  -  have all lit.)
 - Press  to cancel.
-

System settings

Setting the battery type

1 Press  +  to select BATT.

BATT

2 Turn  VALUE to select the battery type.

VALUE

Battery	
ALKL	Alkaline dry cell
NIMH	Nickel-metal hydride rechargeable
LTHM	Lithium dry cell



- Please set this correctly because it effects operation time.
- The remaining charge shown could be higher than the actual amount depending on the type of rechargeable battery.

Setting the automatic power down function

1 Press  +  and select A.PWR.

A.PWR

2 Turn  VALUE to select the automatic power down time.

VALUE

Automatic power down time	
OFF	Automatic power down is disabled.
0.5H	Power will turn off automatically after 30 minutes without operation.
1H	Power will turn off automatically after 1 hour without operation.
3H	Power will turn off automatically after 3 hours without operation.
6H	Power will turn off automatically after 6 hours without operation.

System settings

Setting the headphone gain

- 1 Press  + .

Headphone Gain	
LOUD	Louder output
NORM	Factory default
SOFT	Quieter output

Setting the master tuning

- 1 Press  +  to select TUNE.

TUNE



- 2 Turn  to set the master tuning.



VALUE

Master Tuning
- 75 - 0 - +75 (cents)

System settings

Setting knob movement behavior

- 1 Press  +  to set whether or not latching is used for knob operation.

Latching		
	Jump	When a knob is moved, the parameter changes immediately.
	Latch	The knob does not affect the parameter value until its position reaches that value. Then, the value follows the knob.



- When set to Latch, the dots on the display will be animated to show how much the knob position and parameter value differs to the left or right.

The dots will appear to flow to the left when the parameter value is lower than the knob position and to the right when the value is higher than the position. The flow will be faster for higher values.

System settings

Restoring to factory default settings (factory reset)

- 1 Press and hold EFX^{MODE} + **the POWER switch** to turn on the LIVEN.



- 2 Press **OK**.
The step LEDs will show the progress.
When finished, OK will appear on the display.



- Press **CLR** to cancel.
- This will not restore sample waveform data to the factory default. To restore the sample waveform data, download it from the SONICWARE website and import it.

Checking the system versions

- 1 Press and hold $\text{OCTAVE}^{\text{>}}$ + **the POWER switch** to turn on the LIVEN.



- 2 Press 3/7 , 4/8 and 2/6 to check the versions.

Firmware Versions		
3/7	5 . . Y	System version
4/8	3 . . Y	Boot version
2/6	P . . Y	Preset version

Major version

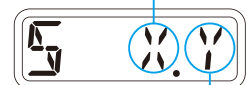

Minor version



- Press the same 3/7 , 4/8 and 2/6 again to show the build number.

System settings

Updating the firmware

- 1 Press and hold  + **the POWER switch** to turn on the LIVEN.



- 2 Transmit the firmware (Sys Ex data) from a PC/Mac.



- The step LEDs show the progress of data transmission. (They light from 1 in order. Transmission is complete when 1 - 16 have all lit.)
-

- 3 After transmission completes, press  to execute the update.



- If the update occurred properly, OK will be shown. (If a problem occurred, an error code will be shown.)
-

- 4 Restart the unit.



- Use new batteries or an AC adapter.
 - Never interrupt the power during a firmware update.
 - Press  to cancel the update and start up normally.
-

System settings

Error codes

<i>ER.10</i>	System error
<i>ER.11</i>	Low battery
<i>ER.20</i>	Data receiving error
<i>ER.21</i>	Invalid data
<i>ER.22</i>	No need to update (Boot)
<i>ER.30</i>	Update Failed

Appendix

Figure 1. Sound architecture

