



ITALTOWER®

HEAVY DUTY LIGHTING TOWERS



Astrid MINE

6x320W LED | 8.5m



LOW EMISSIONS LIGHTING TOWERS

Astrid MINE 6x320W LED | 8.5m

The Astrid Mine is one of ItalTower's best-selling mobile light towers. This mobile light pole is fully equipped. This light pole is very complete as standard with an Amoss kit, day-night sensor and the option to connect to mains power. Thanks to the compact size, as many as 11 light poles can be placed on a trailer. The Astrid Mine is equipped with automatically adjustable lamps for optimal user comfort.



Events

Long autonomy and a very low noise,



Rental

Easy to use, long autonomy and a low fuel consumption



Build

Durable, robust and developed for intensive use.



11x



13,5 m



11x

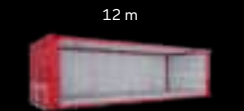

12 m

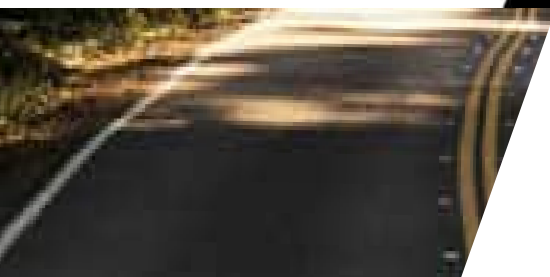
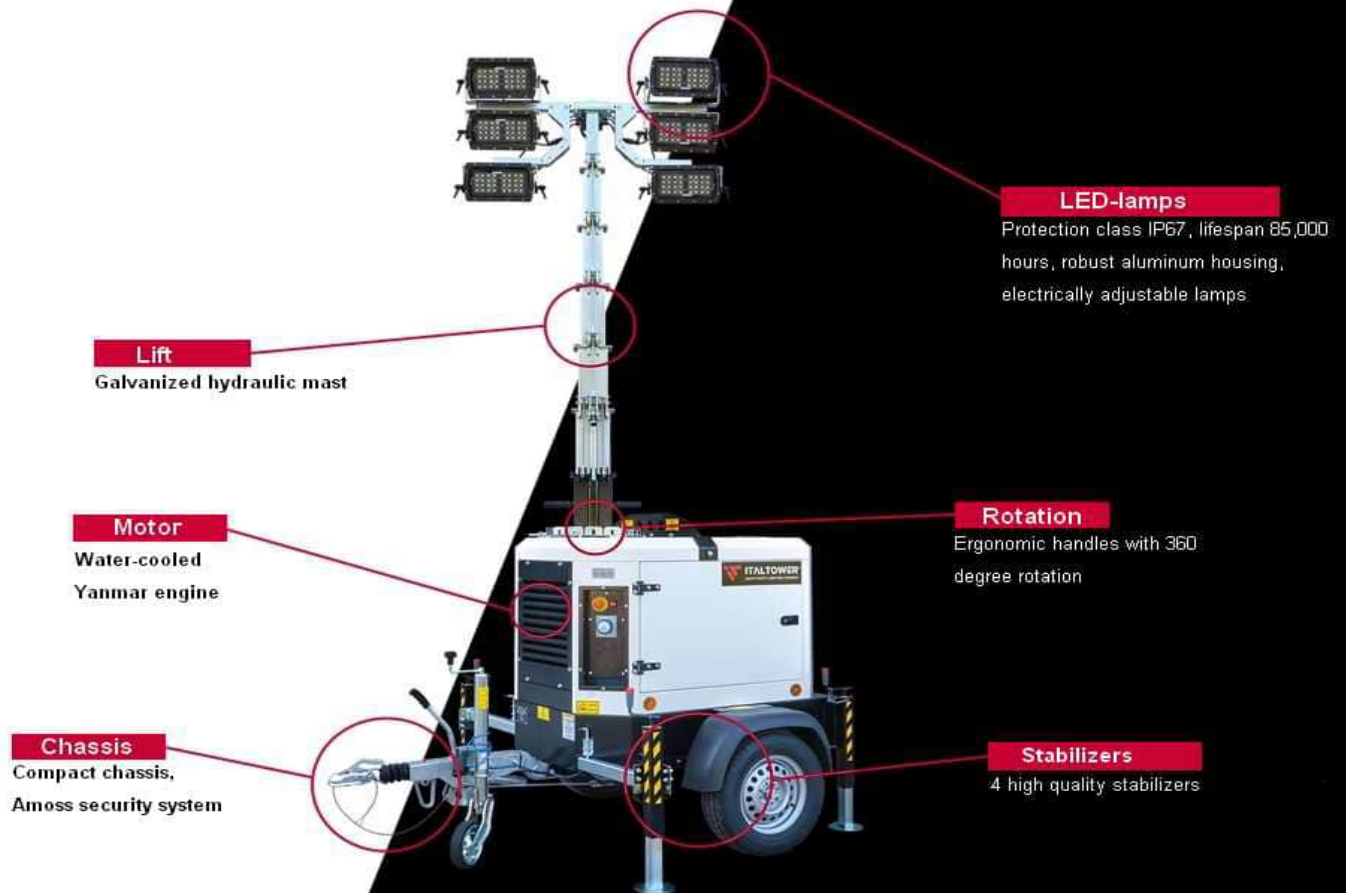
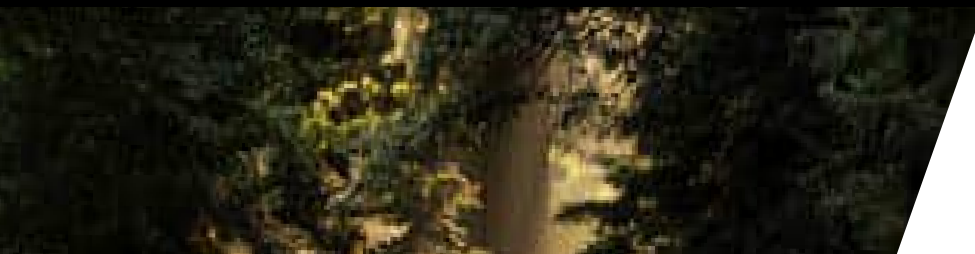



Lights

Lamps	6x 320 Watt LED
Lumen	268.800 lumen
Illuminated surface	7800 m ²

Motor

Model	Yanmar 2TNV70 Diesel
Speed	1500 rpm
Cooling	Water
Cylinders	2
Emission	Stage V

Fuel

Fuel	Diesel
Consumption	0,6 l/hour
Fuel tank capacity	110 litre
Autonomy	183 hour

Generator

Type	Linz Alumen
Output	3,5 Kva
Frequency	50 Hz
Voltage	230 Volt

Mast

Height	8,5 meter
Control	Hydraulic
Rotation	350°
Wind speed	110 km/h

Enclosure and trailer

Trailer	Fast-trailer for public roads
Tyres	185/70/R13
Drip tray	Liquid-tight 110%
Stabilizers	4 + 1 (Tyre)
Preservation	Powder coated

Dimensions and weight

Dimensions retracted LxWxH	220 x 147 x 235 cm.
Dimensions extended LxWxH	220 x 182 x 8500 cm.
Weight	900 kg.

Other

Outlet	1,3 Kva/ 230 volt
Noise level	61 dB
Controller	DeepSea L401
Operating temperature	-30 / + 50° Celcius
Standard options	Amoss-kit Day/night sensor Mains/generator switch

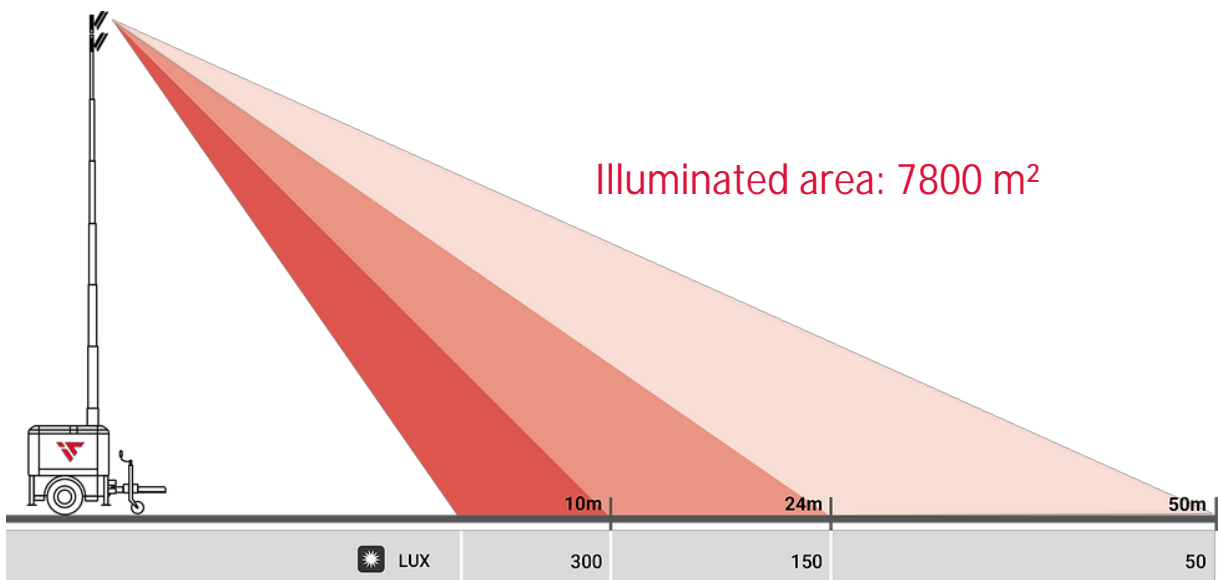
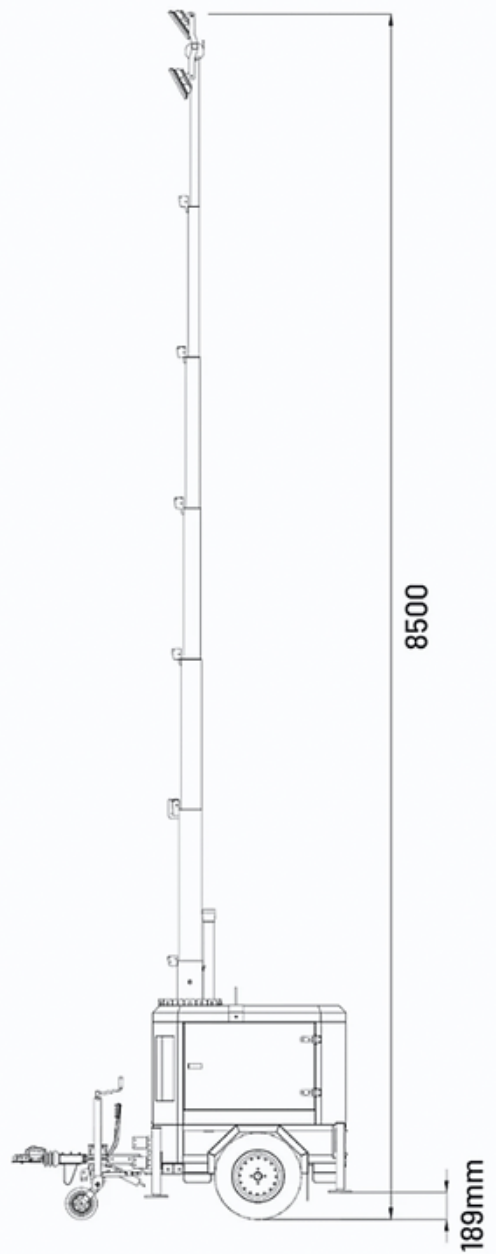
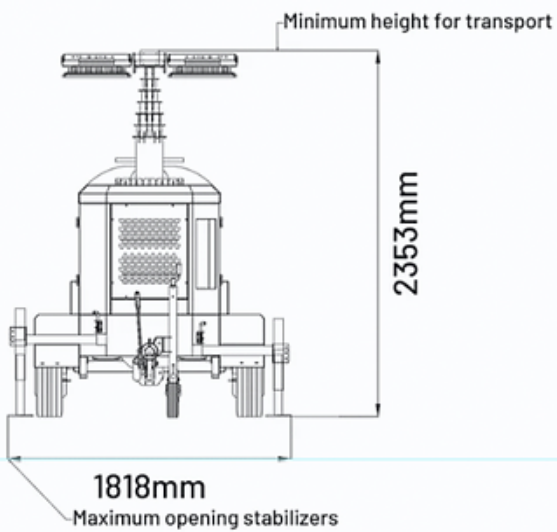
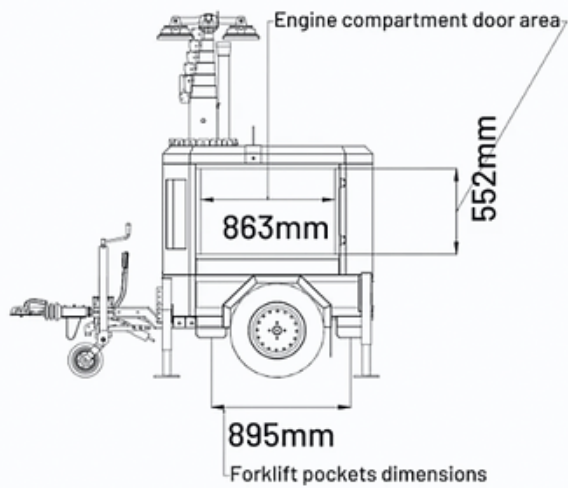





ITALTOWER®

HEAVY DUTY LIGHTING TOWERS

**Italtower Benelux
1 Februariweg 1
4794 SM Heijningen
T: +31 (0) 180 418 113
E: info@diaber.com
W: www.diaber.nl**