



# ITALTOWER®

HEAVY DUTY LIGHTING TOWERS



## Astrid EVO

6x 160W LED | 8.5m



LOW EMISSIONS LIGHTING TOWERS

// **BROCHURE**  
LIGHTING TOWERS 2024

# Astrid EVO 6x160W LED | 8.5m

De Astrid Evo is een van de meest verkochte mobiele lichtmasten van Italtower. Deze mobiele lichtmast is van alle gemakken voorzien. Standaard is deze lichtmast zeer compleet met een Amoss-kit en dag-nachtsensor. Dankzij de compacte afmeting kunnen er maar liefst 11 lichtmasten op een trailer geplaatst worden. De DSE-controller stuurt de Yanmar motor aan en controleert deze voortdurend.



## Evenementen

Lange autonomie, laag geluidsniveau,



## Verhuur

Eenvoudig in gebruik, lange autonomie, laag brandstofverbruik



## Bouw

Duurzaam, robuust en ontwikkeld voor intensief gebruik.

AUTONOMIE

LICHTOPPERVLAKKE

KOSTENBESPARING

FOOTPRINT



11x



13,5 m



11x



12 m

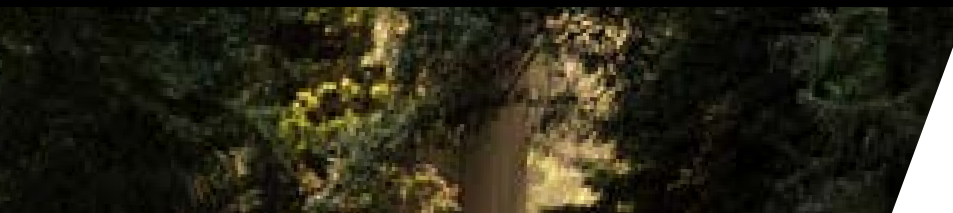

### Lifting

Gegalvaniseerde mast 8,5 meter  
Hydraulische lifting

### Verlichting

Hoogwaardige IP65 LED-lampen.  
Levensduur van 50.000 uur.

### Power

Comap AMF25 Controller  
4 x 200 AH Crystal batterijen

### Rotatie

De mast is eenvoudig te draaien tot 350°  
met twee ergonomische handgrepen.

### Amoss-kit

De mast gaat automatisch omlaag  
als de handrem niet is aangetrokken.

### Stabilisatoren

Hoogwaardige stabilisatoren.  
Eenvoudig in gebruik

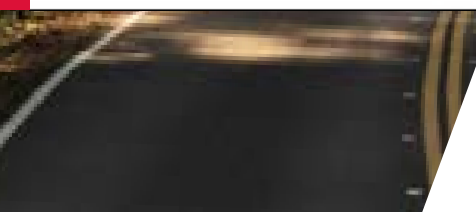



### Verlichting

Lampen	6x 160 Watt LED
Lumen	131.520 lumen
Verlichte oppervlakte	4300 m <sup>2</sup>

### Motor

Model	Yanmar 2TNV70 Diesel
Toerental	1500 rpm
Koeling	Water
Cylinders	2
Emissie	Stage V

### Brandstof

Brandstof	Diesel
Verbruik	0,55 l/uur
Inhoud brandstoftank	110 liter
Autonomie	200 uur

### Generator

Type	Linz Alumen
Output	3,5 Kva
Frequentie	50 Hz
Voltage	230 Volt

### Mast

Hoogte	8,5 meter
Bediening	Hydraulisch
Rotatie	350°
Windsnelheid	110 km/u

### Omkastings en trailer

Trailer	Fast-trailer voor openbare weg
Banden	185/70/R13
Lekbak	Vloeistofdicht 110%
Stabilisatoren	4 + 1 (wiel)
Conservering	Gepoedercoat

### Afmetingen

Afmeting ingeschoven LxBxH	220 x 147 x 235 cm.
Afmeting uitgeschoven LxBxH	220 x 182 x 8500 cm.

### Overige

Outlet	1,3 Kva/ 230 volt Geluidsniveau
61 dB	
Controller	DeepSea L401
Gebruikstemperatuur	-30 / + 50° Celcius
Standaard opties	Amoss-kit Dag/ nachtsensor Switch netstroom / generator

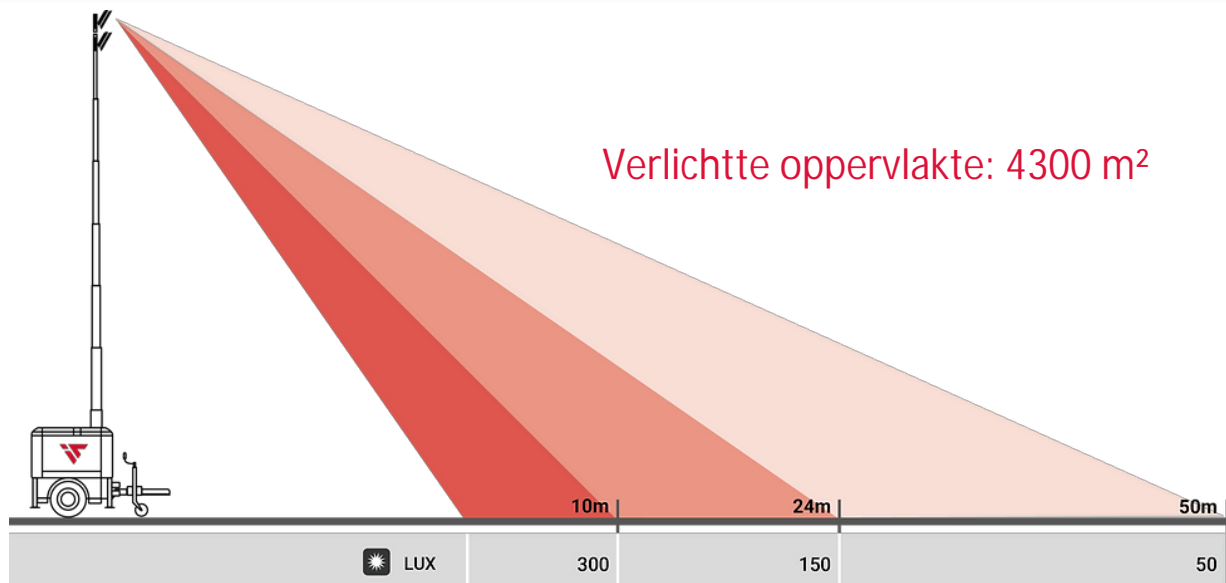
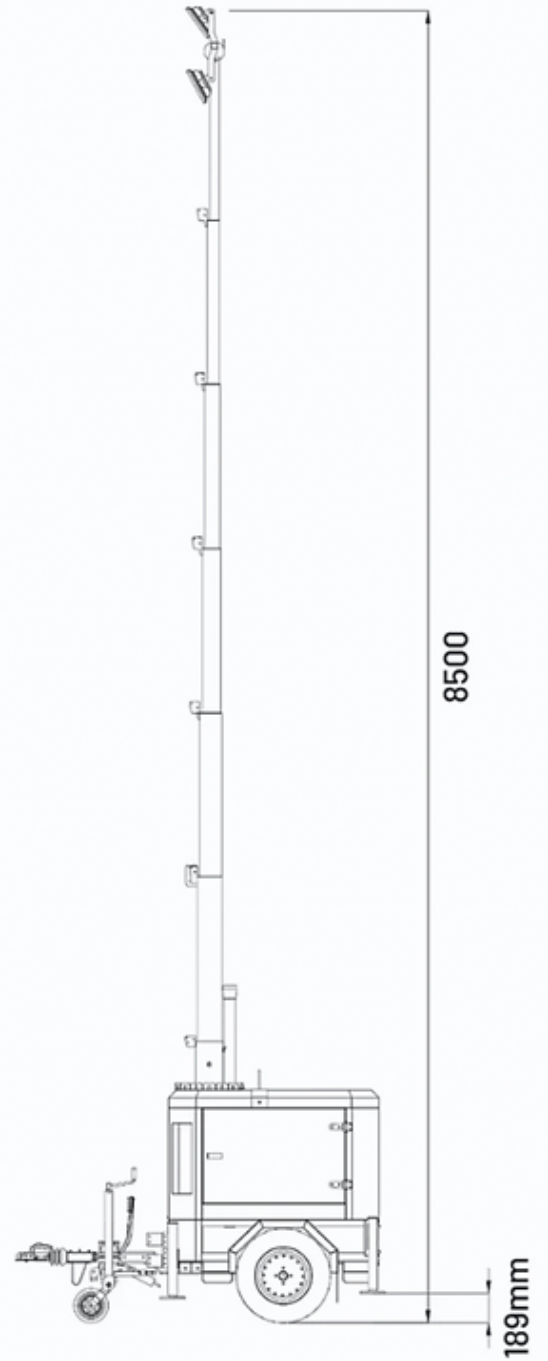
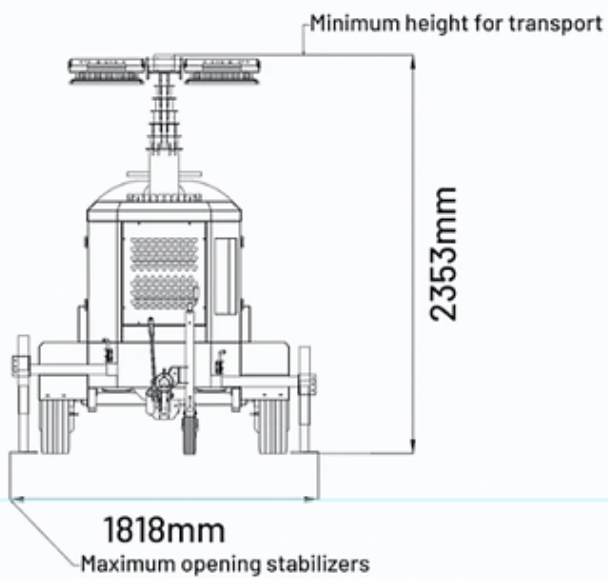
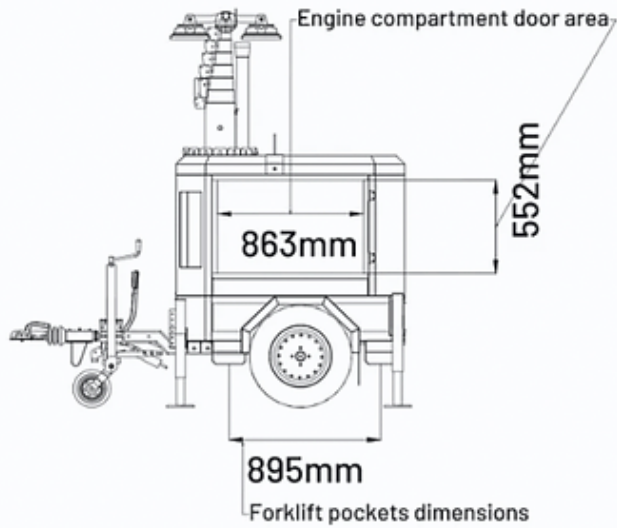



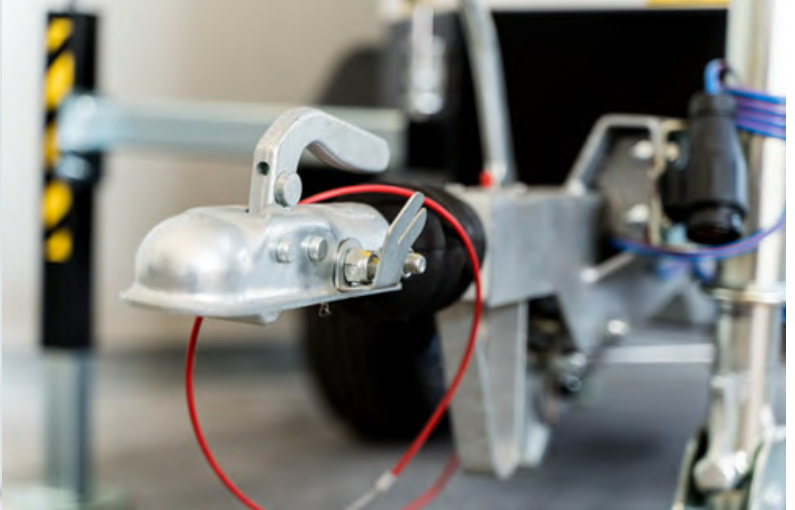



# **ITALTOWER®**

**HEAVY DUTY LIGHTING TOWERS**

**Italtower Benelux  
1 Februariweg 1  
4794 SM Heijningen  
T: +31 (0) 180 418 113  
E: [info@diaber.com](mailto:info@diaber.com)  
W: [www.diaber.nl](http://www.diaber.nl)**