

Advanced Credit Management (1QM)

This scope item supports the following processes:

01 - Main

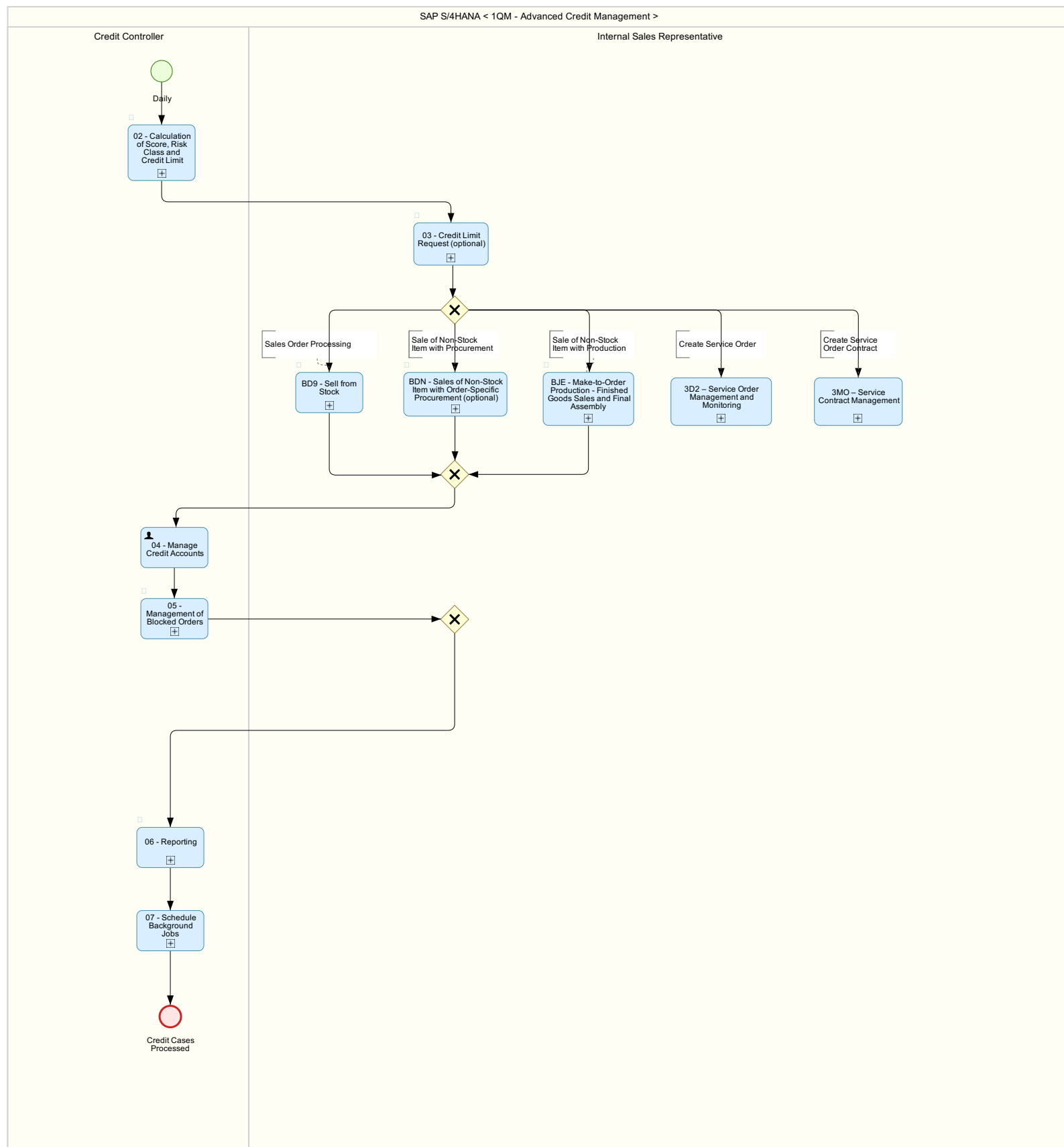

02 - Calculation of Score, Risk Class and Credit Limit

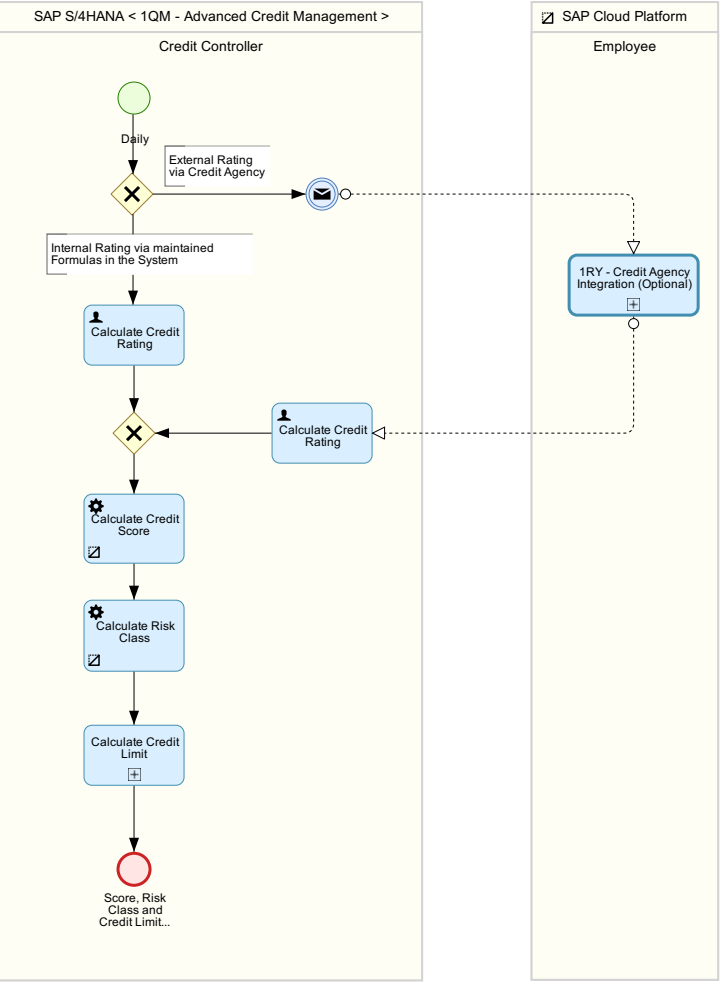

03 - Credit Limit Request

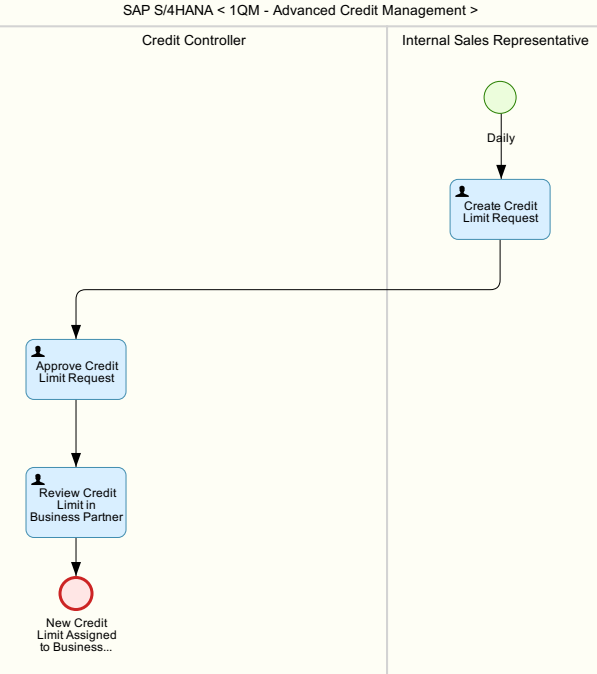

04 - Manage Credit Accounts

1QM - Advanced Credit Management

Credit Controller

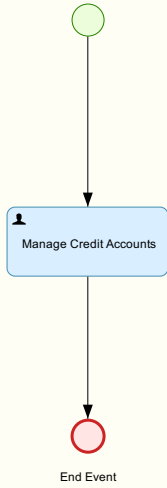

05 - Management of Blocked Orders

SAP S/4HANA < 1QM - Advanced Credit Management >

Internal Sales Representative

Credit Controller

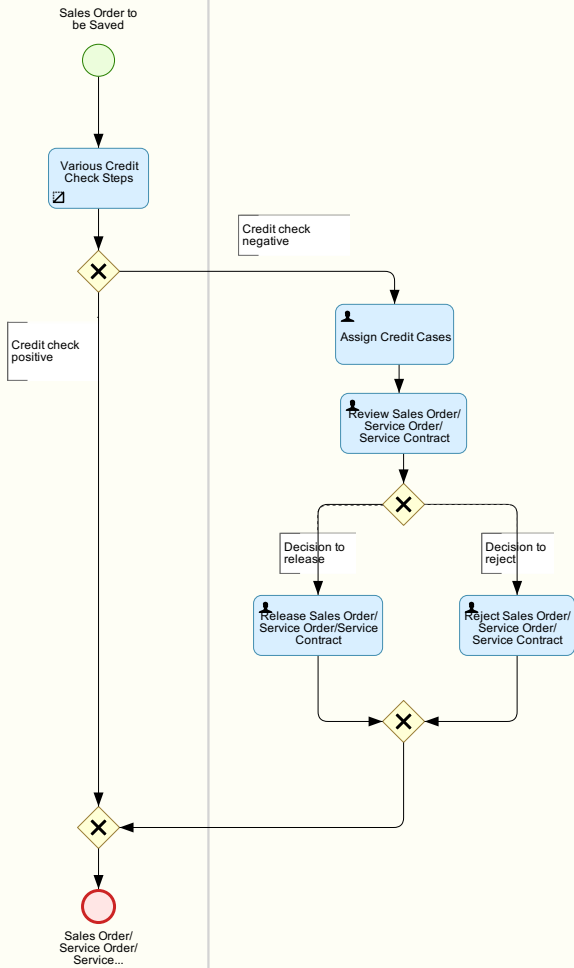

06 - Reporting

Credit Controller

Daily Reporting

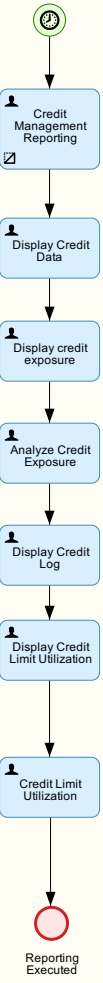

1QM - Advanced Credit Management

Credit Controller

